

Digi-Pas[®]

Installation and Operation Guidelines for DWL5000XY, DWL5500XY and DWL5800XY Tilt Sensor Modules

Rev. 2.6.0

CONTENT

- 1. Introduction 1
 - 1.1. Overview 1
 - 1.2. Technical Specification 1
 - 1.3. Dimension of the Tilt Sensor Module 2
 - 1.4. Pinout if the Tilt Sensor Module and Sensor Cord 3
- 2. Installation 4
 - 2.1. Securing Tilt Sensor Module with Sensor Cord 4
 - 2.2. Mounting the Tilt Sensor Module 4
- 3. Configuration 5
 - 3.1. Configuration of Sensor Module(s) with Control Box 5
 - 3.1.1. Connection using USB through 5x000XY Control Box 6
 - 3.1.2. Connection using Bluetooth through 5x000XY Control Box 7
 - 3.1.3. Connection using serial converter (RS485) 7
 - 3.1.4. Connection using serial converter (RS232) 10
 - 3.2. Configuration of Single Tilt Sensor Module with Converter 12
 - 3.2.1. Configuration Setup Procedure (RS485) 13
- 4. Operation 14
 - 4.1. Installation of the DWL5X00XY Pc Sync Software 14
 - 4.2. Operation of Single Tilt Sensor Module with Converter 16
 - 4.3. Operation of Sensor Module(s) with Control Box 16
 - 4.4. Direction of the Single-Axis and Dual-Axis Measured Angle 17
- 5. Dynamic-Link Libraries For DWL5X00XY Tilt Sensor Module Notes 18
 - 5.1. Introduction 18
 - 5.1.1. Absolute Level in Single & Dual Axis Mode Calculation 18
 - 5.2. DLL for Serial Communication Protocol Direct to Sensor 19
 - 5.2.1. Using the DWL5000XY Dynamic Link Library 19
 - 5.2.1.1. DWL5000XYLibrary.SerialComm.Serial_Initialization 19
 - 5.2.1.2. DWL5000XYLibrary.SerialComm.Mode_Direct 20

5.2.1.3. DWL5000XYLibrary.SerialComm.Stand.....	20
5.2.1.4. DWL5000XYLibrary.SerialComm.Sensor_Connection_Status.....	21
5.2.1.5. DWL5000XYLibrary.SerialComm.Dual_X_Value.....	21
5.2.1.6. DWL5000XYLibrary.SerialComm.Dual_Y_Value.....	22
5.2.1.7. DWL5000XYLibrary.SerialComm.Single_Value.....	22
5.2.1.8. DWL5000XYLibrary.SerialComm.Vibro_Value.....	23
5.2.1.9. DWL5000XYLibrary.SerialComm.Dual_Alt_Zero_Set.....	23
5.2.1.10. DWL5000XYLibrary.SerialComm.Dual_Alt_Zero_Clear.....	24
5.2.1.11. DWL5000XYLibrary.SerialComm.Dual_X_Alt_Zero_Value.....	24
5.2.1.12. DWL5000XYLibrary.SerialComm.Dual_Y_Alt_Zero_Value.....	24
5.2.1.13. DWL5000XYLibrary.SerialComm.Single_Alt_Zero_Set.....	25
5.2.1.14. DWL5000XYLibrary.SerialComm.Single_Alt_Zero_clear.....	25
5.2.1.15. DWL5000XYLibrary.SerialComm.Single_Alt_Zero_Value.....	25
5.2.2. Using the DWL5500XY Dynamic Link Library.....	26
5.2.2.1. DWL5500XYLibrary.SerialComm.Serial_Initialization.....	26
5.2.2.2. DWL5500XYLibrary.SerialComm.Mode_Direct.....	26
5.2.2.3. DWL5500XYLibrary.SerialComm.set_location.....	27
5.2.2.4. DWL5500XYLibrary.SerialComm.Stand.....	27
5.2.2.5. DWL5500XYLibrary.SerialComm.Sensor_Connection_Status.....	28
5.2.2.6. DWL5500XYLibrary.SerialComm.Dual_X_Value.....	28
5.2.2.7. DWL5500XYLibrary.SerialComm.Dual_Y_Value.....	29
5.2.2.8. DWL5500XYLibrary.SerialComm.Single_Value.....	29
5.2.2.9. DWL5500XYLibrary.SerialComm.Vibro_Value.....	30
5.2.2.10. DWL5500XYLibrary.SerialComm.Single_Alt_Zero_Set.....	30
5.2.2.11. DWL5500XYLibrary.SerialComm.Single_Alt_Zero_clear.....	30
5.2.2.12. DWL5500XYLibrary.SerialComm.Single_Alt_Zero_Value.....	31
5.2.2.13. DWL5500XYLibrary.SerialComm.Dual_Alt_Zero_Set.....	31
5.2.2.14. DWL5500XYLibrary.SerialComm.Dual_Alt_Zero_Clear.....	32

5.2.2.15. DWL5500XYLibrary.SerialComm.Dual_x_Alt_Zero_Value	32
5.2.2.16. DWL5500XYLibrary.SerialComm.Dual_y_Alt_Zero_Value	32
5.3. DLL for Serial Communication Protocol for Digi-Pas Control Box	33
5.3.1. Using the DWL5000XY Dynamic Link Library	33
5.3.1.1. DWL5000XYLibrary.SerialComm.Serial_Initialization	33
5.3.1.2. DWL5000XYLibrary.SerialComm.Mode	34
5.3.1.3. DWL5000XYLibrary.SerialComm.Stand	34
5.3.1.4. DWL5000XYLibrary.SerialComm.Sensor_Connection_Status	35
5.3.1.5. DWL5000XYLibrary.SerialComm.Dual_X_Value	36
5.3.1.6. DWL5000XYLibrary.SerialComm.Dual_Y_Value	36
5.3.1.7. DWL5000XYLibrary.SerialComm.Single_Value	37
5.3.1.8. DWL5000XYLibrary.SerialComm.Vibro_Value	37
5.3.1.9. DWL5000XYLibrary.SerialComm.Dual_Alt_Zero_Set	37
5.3.1.10. DWL5000XYLibrary.SerialComm.Dual_Alt_Zero_Clear	37
5.3.1.11. DWL5000XYLibrary.SerialComm.Dual_x_Alt_Zero_Value	38
5.3.1.12. DWL5000XYLibrary.SerialComm.Dual_y_Alt_Zero_Value	38
5.3.1.13. DWL5000XYLibrary.SerialComm.Single_Alt_Zero_Set	39
5.3.1.14. DWL5000XYLibrary.SerialComm.Single_Alt_Zero_clear	39
5.3.1.15. DWL5000XYLibrary.SerialComm.Single_Alt_Zero_Value	39
5.3.2. Using the DWL5500XY Dynamic Link Library	40
5.3.2.1. DWL5500XYLibrary.SerialComm.Serial_Initialization	40
5.3.2.2. DWL5500XYLibrary.SerialComm.Mode	40
5.3.2.3. DWL5500XYLibrary.SerialComm.set_location	41
5.3.2.4. DWL5500XYLibrary.SerialComm.Stand	41
5.3.2.5. DWL5500XYLibrary.SerialComm.Sensor_Connection_Status	41
5.3.2.6. DWL5500XYLibrary.SerialComm.Dual_X_Value	42
5.3.2.7. DWL5500XYLibrary.SerialComm.Dual_Y_Value	42

5.3.2.8. DWL5500XYLibrary.SerialComm.Single_Value	43
5.3.2.9. DWL5500XYLibrary.SerialComm.Vibro_Value.....	43
5.3.2.10. DWL5500XYLibrary.SerialComm.Single_Alt_Zero_Set	44
5.3.2.11. DWL5500XYLibrary.SerialComm.Single_Alt_Zero_clear	44
5.3.2.12. DWL5500XYLibrary.SerialComm.Single_Alt_Zero_Value.....	44
5.3.2.13. DWL5500XYLibrary.SerialComm.Dual_Alt_Zero_Set.....	45
5.3.2.14. DWL5500XYLibrary.SerialComm.Dual_Alt_Zero_Clear	45
5.3.2.15. DWL5500XYLibrary.SerialComm.Dual_x_Alt_Zero_Value	45
5.3.2.16. DWL5500XYLibrary.SerialComm.Dual_y_Alt_Zero_Value	46
6. RS485/232 Serial Communication Protocol for Single DWL5x00XY Tilt Sensor.....	46
6.1. Serial Port Settings	47
6.2. Buffer Frame Format	47
6.3. Initialization Command	47
6.4. Commands for Source and Destination	47
6.5. Commands for Mode Selection.....	48
6.5.1. Single Axis Mode	48
6.5.2. Dual Axis Mode	49
6.5.3. Vibro Mode.....	50
6.5.4. Calibration Mode	51
6.5.4.1. Detailed Calibration Steps.....	52
6.5.5. Absolute Level in Single & Dual Axis Mode Calculation	52
6.5.6. Location Setting.....	52
7. Serial Communication Protocol for Control Box.....	58
7.1. Serial Port Settings	58
7.2. Buffer Frame Format	58
7.3. Commands for Source and Destination	59
7.4. Commands for Mode Selection.....	59
7.4.1. Single Axis Mode	60

7.4.2. Dual Axis Mode61

7.4.3. Vibro Mode.....62

7.4.4. Calibration Mode63

7.4.4.1. Detailed Calibration Steps 64

7.4.5. Relay Mode65

APPENDIX 1: User Calibration70

APPENDIX 2 : Country & City Index71

8. Warranty.....78

APPLICATION DIAGRAM

Application diagram 1 - Multiple sensors

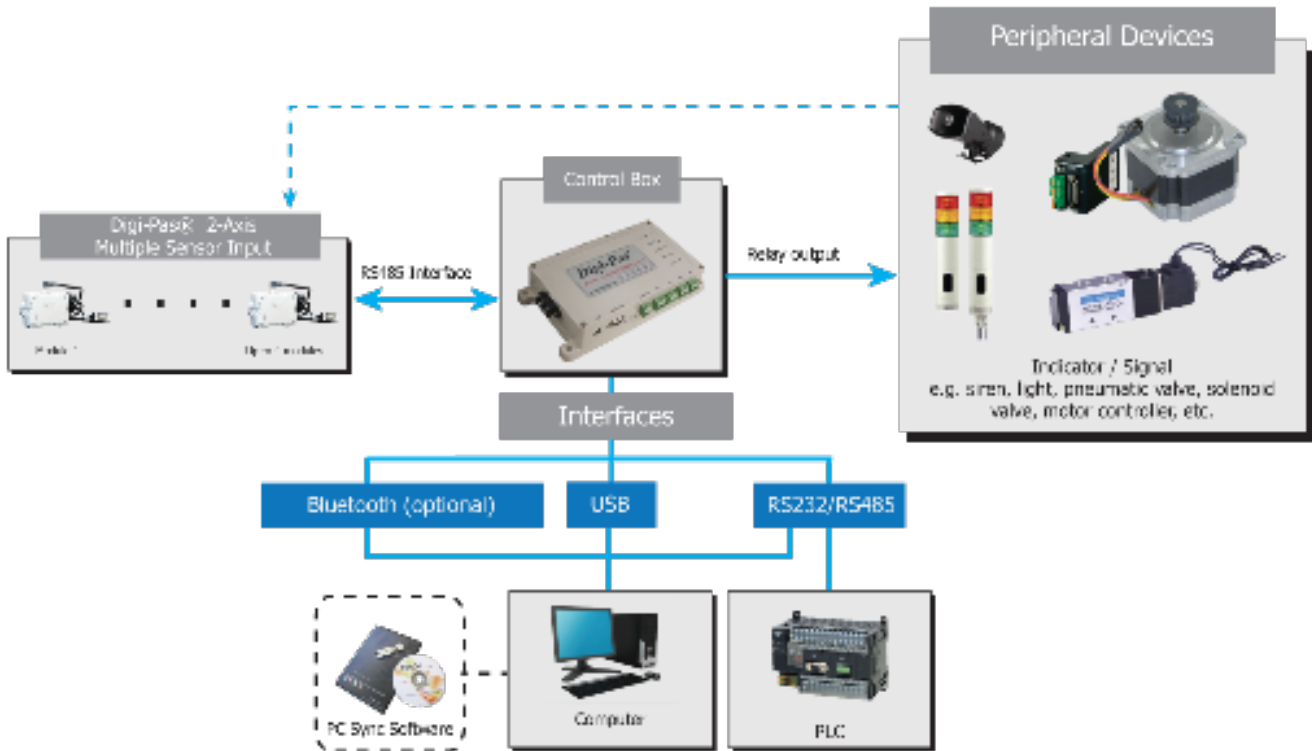

Application diagram 2 - Single Sensor

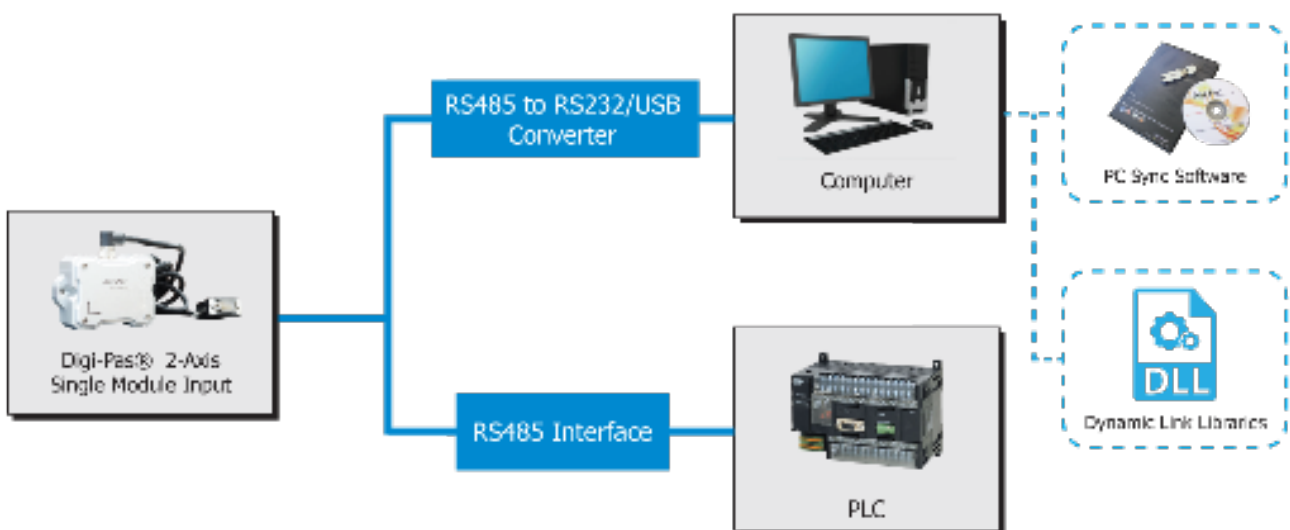

1. Introduction

1.1. Overview

Digi-Pas® DWL5000XY, DWL5500XY & DWL-5800XY are 2-Axis Precision tilt Sensor Modules that specifically designed to be integrated into a machine/equipment/structure for real-time simultaneous monitoring, data acquisition & logging of a plane levelling state, 2D tilt angles & vibration measurements.

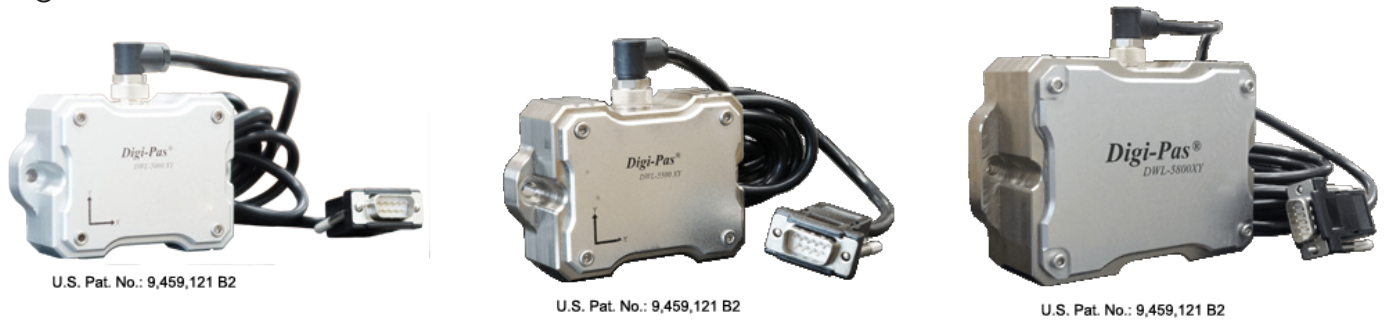

Figure 1. (a) DWL5000XY (b) DWL5500XY (c) DWL5800XY tilt sensor module

1.2. Technical Specification

	DWL-5000XY	DWL-5500XY	DWL-5800XY
Dimension	90mm × 60mm × 30mm		120 x 80 x 43
Weight (Approx.)	400g	600g	1200g
Measuring Range	0° ~ ±90.00° (Single-Axis) 0° ~ ±15.00° (Dual-Axis)	0° ~ ±10.000° (Single-Axis) 0° ~ ±5.000° (Dual-Axis)	0° ~ ±14400arcsec (Single-Axis) 0° ~ ±3600 arcsec (Dual-Axis)
Resolution	0.01° (175 μm/M) (0.002 in/feet)	0.001° (18 μm/M) (0.0002 in/feet)	1 arcsec; (≤5 μm/M)
Accuracy	± 0.01° at 0° to 2.00° ± 0.03° at other angles	± 0.001° at 0° to 2.000° ± 0.003° at other angles	± 1 arcsec; at 0 to ±1080 arcsec.; 3 arcsec at other angles
Vibrometer	1.0g	2.0g	2.0g
Settling Time ≤ 10° (Degree)	6 Seconds	20 Seconds	30 Seconds
Input Voltage	Regulated 9V DC		
Maximum Load	150mA		
Output Mode	RS485 *USB, RS232, RS485 and SPDT Relay *Wireless Bluetooth connectivity (optional)		
Waterproof Rating	IP65		
Operating	-20°C to +70°C		10°C to +40°C
Storage	-30°C to +80°C		-30°C to +80°C

Table 1. Technical specification of DWL5000XY, DWL5500XY & DWL5800XY tilt sensor module

Notes:

- Product specification and appearance are subject to change for product improvement without prior notice.
- *Control Box is required

1.3. Dimension of the Tilt Sensor Module

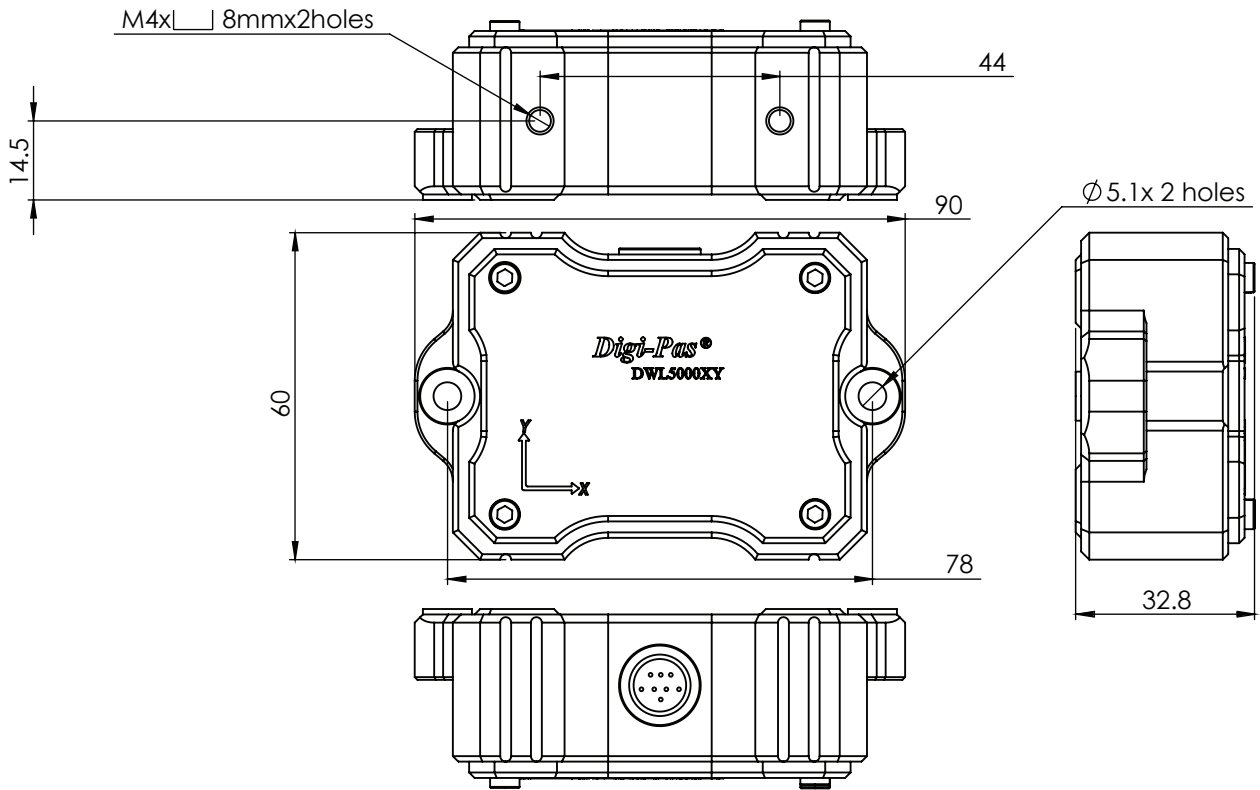

Figure 2. DWL-5000XY & DWL 5500XY Tilt Sensor Dimension

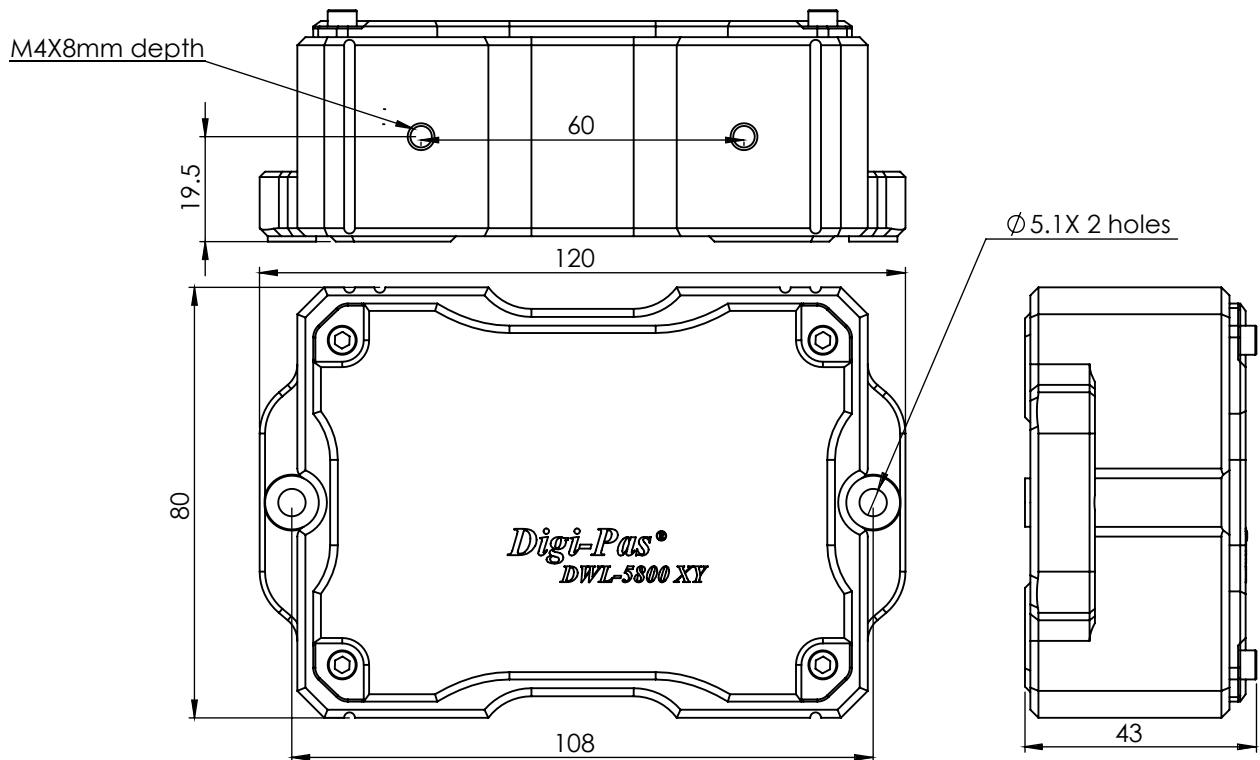

Figure 3. DWL 5800XY Tilt Sensor Dimension

1.4. Pinout of the Tilt Sensor Module and Sensor Cord

Pinout of the circular multipole connector from tilt sensor module is shown in Figure 4

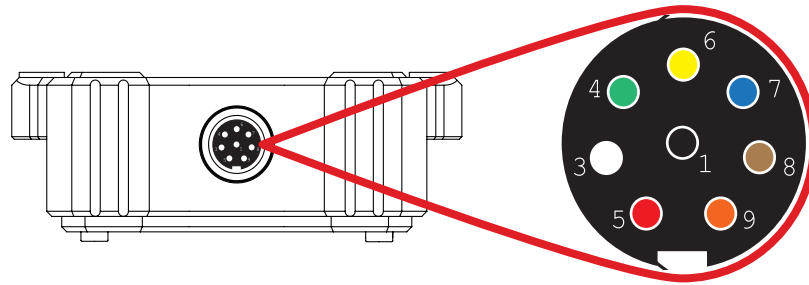

Figure 4. Pinout of the circular multipole connector of the tilt sensor module

NOTE



User can customize their own cable, the specification and part number of the circular connector for the sensor module cable as below:

Manufacturer : BINDER
P/N : 99 0425 70 08

Pinout of the sensor cord is shown in Figure 5

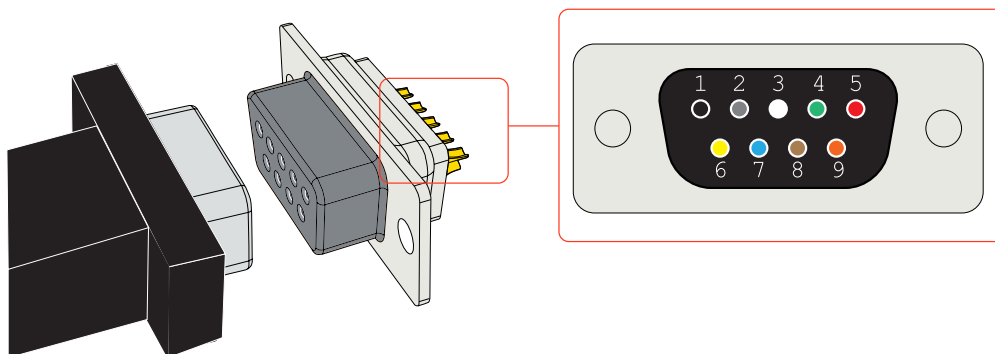

Figure 5. Pinout of the sensor cord (DB-9)

Pin No.	Description
1	GND
2	N.C (No Connection)
3	GND (without Control Box) or Signal 1 (For Control Box only)
4	GND (without Control Box) or Signal 2 (For Control Box only)
5	Power Input (Regulated 9V DC)
6	RS485 - A (Non-inverting Receiver Input/Tx+)
7	RS485 - B (Inverting Receiver Input/Tx-)
8	RS485 - Z (Inverting Driver Output)/Rx- or RS232 - Rx
9	RS485 - Y (Noninverting Driver Output / Rx+) or RS232 - Tx

*Please verify the connection before power on the device. Wrong connection will lead to device failure and may void your warranty.

2. Installation

2.1. Securing Tilt Sensor Module with Sensor Cord

1. Ensure the circular multipole connector is aligned to the receptacle on the sensor module as illustrated on Figure 6(a).
2. Secure the rotatable ring by turning it clockwise as in Figure 6(b).

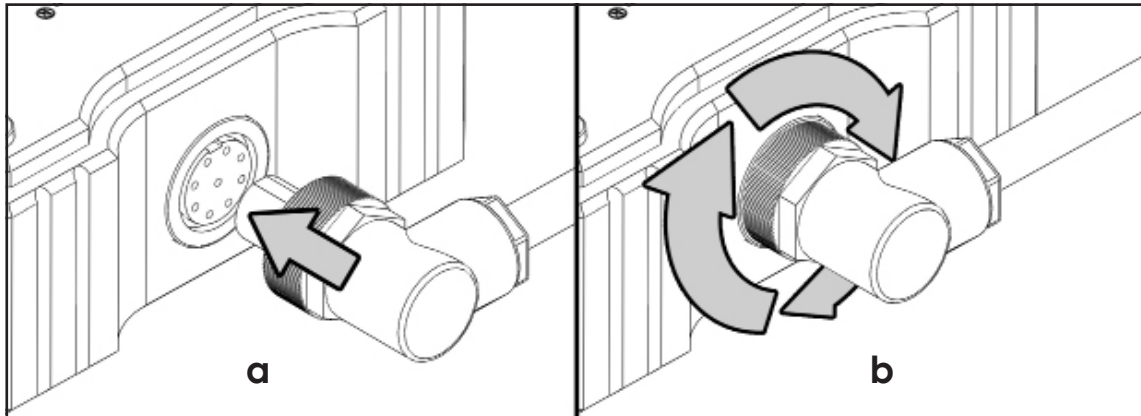

Figure 6. Steps to secure the tilt sensor module with sensor cord

2.2. Mounting the Tilt Sensor Module

1. Two threaded holes (M4) are provided to mount the tilt sensor module in Single Axis onto user-defined fixtures/machinery.

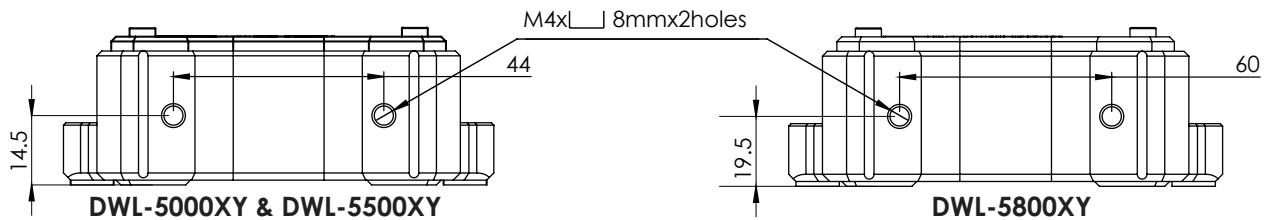

Figure 7. Two threaded holes (M4) is provided to mount the tilt sensor module in Single Axis

2. Two threaded holes (M4) are provided to mount the tilt sensor module in Single Axis onto user-defined fixtures/machinery.

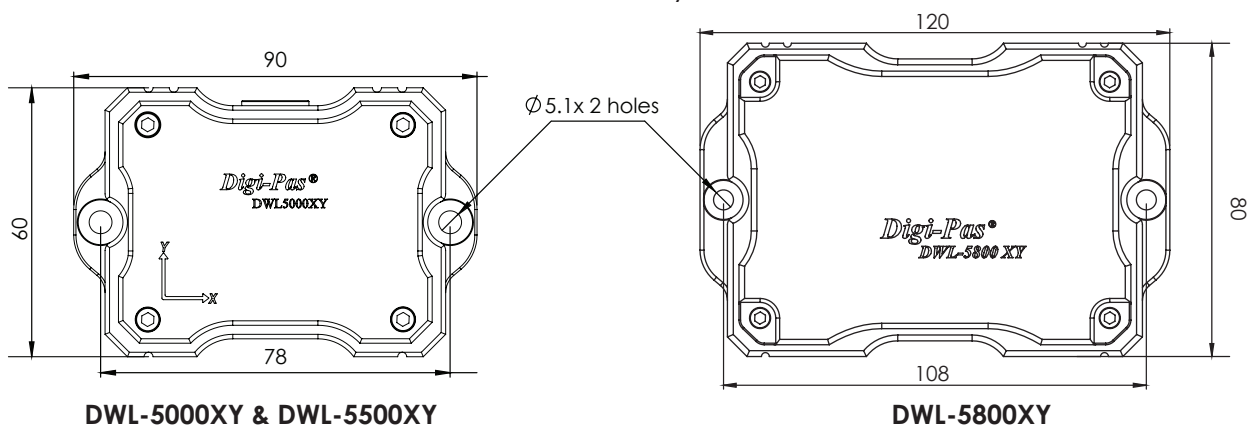

Figure 8. Two 5.1mm diameter holes is provided to mount the tilt sensor module in Single Axis

3. Configuration

This section deliberates how to configure the tilt sensor module to communicate with PC, machine or equipment. Visit <https://www.digipas.com/support/video.php> to view how to use the control box with DWL-5x000XY sensor.

3.1. Configuration of Sensor Module(s) with Control Box

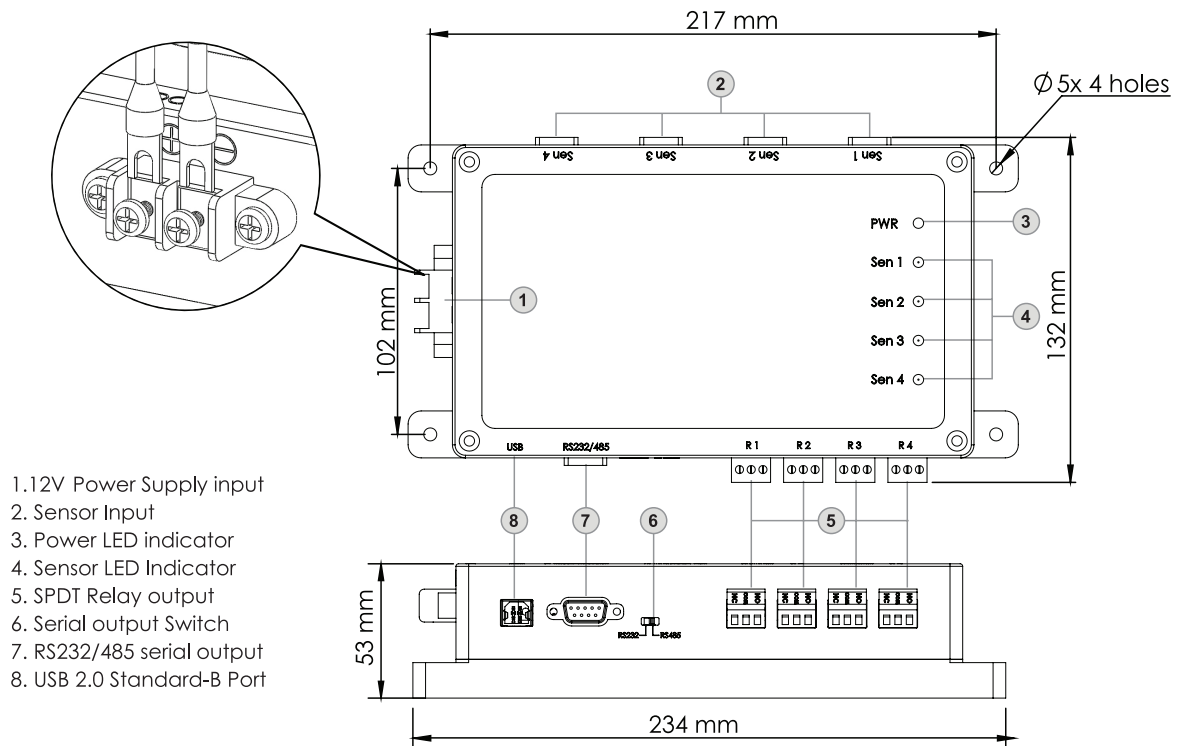

Figure 9. Overview of the Control Box

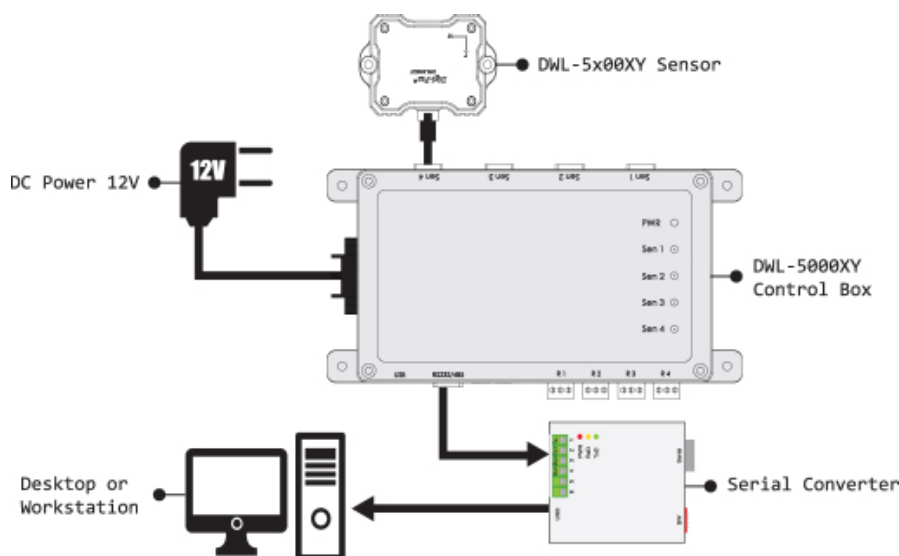

Figure 10. Diagram overview of serial connection through control box using and ES-U-3001-M serial converter

3.1.1. Connection using USB through 5x000XY Control Box

3.1.1.1. Materials for the Configuration

- 1 × DWL5000XY, DWL5500XY, or DWL5800XY tilt sensor module secured with sensor cord
- 1 × 12V DC Power Source
- 1 × Digi-Pas DWL5x00XY control box
- 1 × USB cable

3.1.1.2. Configuration Setup Procedure

1. Secure the sensor cord with tilt sensor module as stated in [2.1 Securing Tilt Sensor Module with Sensor Cord](#).
2. Connect the sensor cord to the sensor input on the Digi-Pas DWL5x00XY control box.
3. Source in regulated 12V DC to the power supply input.
4. The Power LED (PWR) of the control box lights in orange color. Once the initialization between the sensor module and the control box is completed, the Power LED turns yellow. The Sensor LED (SEN 1, SEN 2, SEN 3, SEN 4) on the respective sensor lights up in green color. If the connection between the tilt sensor module and control box is lost, the Power LED lights up in red.
5. Connect the USB cable from USB2.0 Standard-B Port on the control box to the PC as shown in Figure 11.

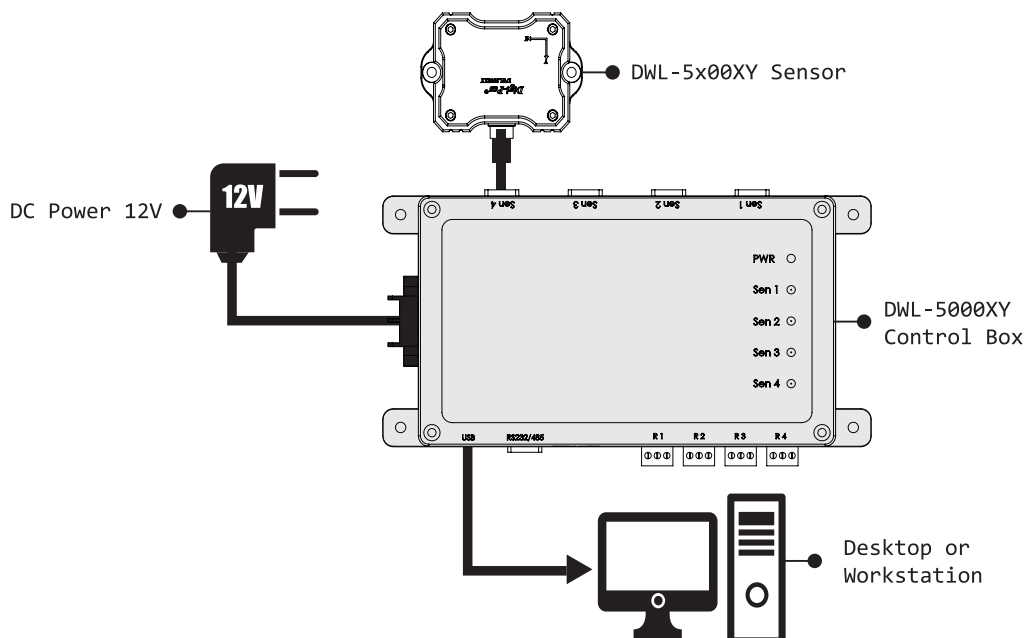

Figure 11. Diagram for USB connection through control box using and ES-U-3001-M serial converter

6. The configuration is then completed. Users can obtain data through PC Sync software please refer to [“4. Operation”](#)

3.1.2. Connection using Bluetooth through 5x000XY Control Box

3.1.2.1. Materials for the Configuration

- 1 × DWL5000XY, DWL5500XY, or DWL5800XY tilt sensor module secured with sensor cord
- 1 × 12V DC Power Source
- 1 × Digi-Pas DWL5x00XY control box

3.1.2.2. Configuration Setup Procedure

1. Secure the sensor cord with tilt sensor module as stated in [2.1 Securing Tilt Sensor Module with Sensor Cord](#).
2. Connect the sensor cord to the sensor input on the Digi-Pas DWL5x00XY control box.
3. Source in regulated 12V DC to the power supply input.
4. The Power LED (PWR) of the control box lights in orange color. Once the initialization between the sensor module and the control box is completed, the Power LED turns yellow. The Sensor LED (SEN 1, SEN 2, SEN 3, SEN 4) on the respective sensor lights up in green color. If the connection between the tilt sensor module and control box is lost, the Power LED lights up in red.
5. The configuration is then completed. Users can obtain data through PC Sync software please refer to "[4. Operation](#)"

3.1.3. Connection using serial converter (RS485)

3.1.3.1. Materials for the Configuration

- 1 × DWL5000XY, DWL5500XY, or DWL5800XY tilt sensor module secured with sensor cord
- 1 × 12V DC Power Source
- 1 × Digi-Pas DWL5x00XY control box
- 1 × RS485 converter In this example, EasySync Converter (Model number: ES-U-3001-M) is used.
- Computer/Workstation with or without PC Sync software installed.

3.1.3.2. Configuration Setup Procedure

1. Secure the sensor cord with tilt sensor module as stated in [2.1 Securing Tilt Sensor Module with Sensor Cord](#).
2. Connect the sensor cord to the sensor input on the Digi-Pas DWL5x00XY control box.
3. Source in regulated 12V DC to the power supply input for Control Box.
4. The Power LED (PWR) of the control box lights in orange color. Once the initialization between the sensor module and the control box is completed, the Power LED turns yellow. The Sensor LED (SEN 1, SEN 2, SEN 3, SEN 4) on the respective sensor lights up in green color. If the connection between the tilt sensor module and control box is lost, the Power

LED lights up in red.

5. Select the Serial output Switch on the control box (refer to Figure 12) to RS485.

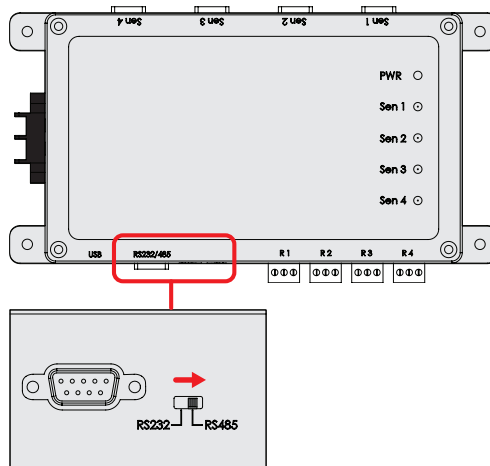

Figure 12. Changing control box output to support RS485 connection

6. Connect the cable from RS485 serial output on the control box to ES-U-3001-M converter as in figure 13.

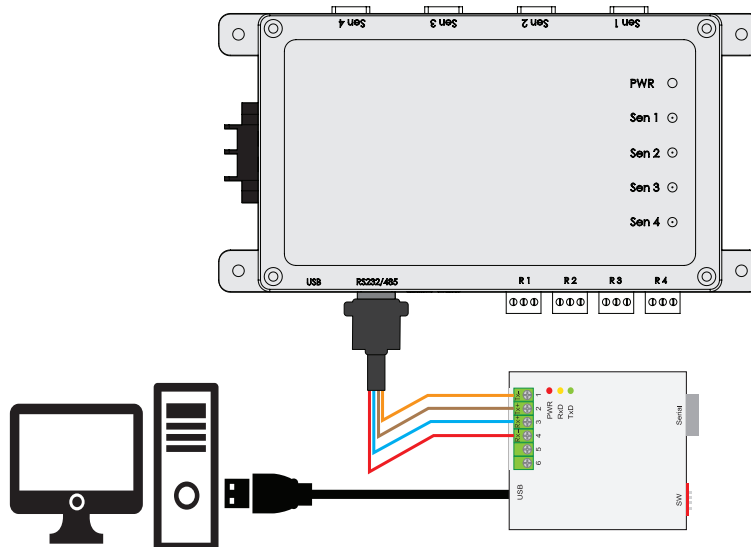
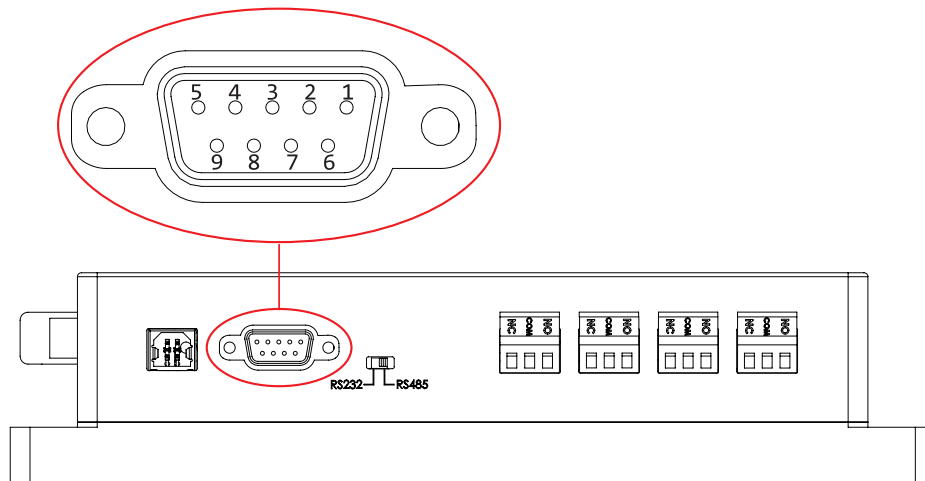

Figure 13. Diagram RS485 Serial connection through control box using and ES-U-3001-M serial converter to PC

7. The connection wiring pinout of the control box RS485 serial output is illustrated in Figure 14.



Pin No.	Description
1	NC
2	RS485 - A (Non-inverting Receiver Input/Tx+)
3	RS485 - B (Inverting Receiver Input/Tx-)
4	RS485 - Z (Inverting Driver Output)/Rx-
5	RS485 - Y (Noninverting Driver Output / Rx+)
6	GND
7	NC
8	RS232 - Receiver Input (Rx)
9	RS232 - Transmitter Output (Tx)

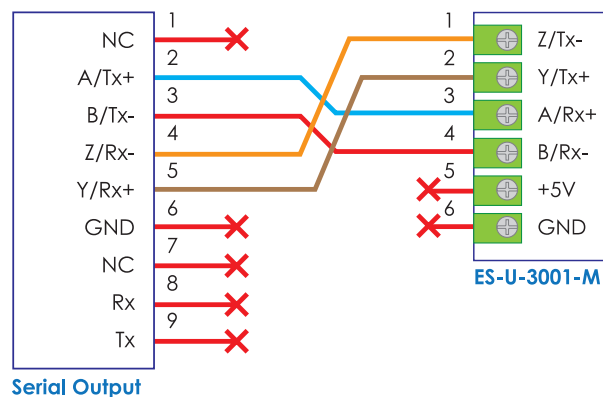

Figure 14. The connection pinout of RS485 Serial Output with ES-U-3001-M converter in RS485 mode

- The configuration is then completed. The configuration is then completed. Users can obtain data through PC Sync software please refer to "4. Operation", using Digi-Pas DLL refer to "5.2 . DLL for Serial Communication Protocol Direct to Sensor" or direct programming refer to "7. Serial Communication Protocol for Control Box"

3.1.4. Connection using serial converter (RS232)

3.1.4.1. Materials for the Configuration

- 1 × DWL5000XY, DWL5500XY, or DWL5800XY tilt sensor module secured with sensor cord
- 1 × 12V DC Power Source
- 1 × Digi-Pas DWL5x00XY control box
- 1 × RS232 converter. In this example we are EasySync Converter (Model number: ES-U-3001-M) is used.

3.1.4.2. Configuration Setup Procedure

1. Secure the sensor cord with tilt sensor module as stated in [2.1 Securing Tilt Sensor Module with Sensor Cord](#).
2. Connect the sensor cord to the sensor input on the Digi-Pas DWL5x00XY control box.
3. Source in regulated 12V DC to the power supply input for Control Box.
4. The Power LED (PWR) of the control box lights in orange color. Once the initialization between the sensor module and the control box is completed, the Power LED turns yellow. The Sensor LED (SEN 1, SEN 2, SEN 3, SEN 4) on the respective sensor lights up in green color. If the connection between the tilt sensor module and control box is lost, the Power LED lights up in red.
5. Select the Serial output Switch on the control box (refer to Figure 15) to RS232.

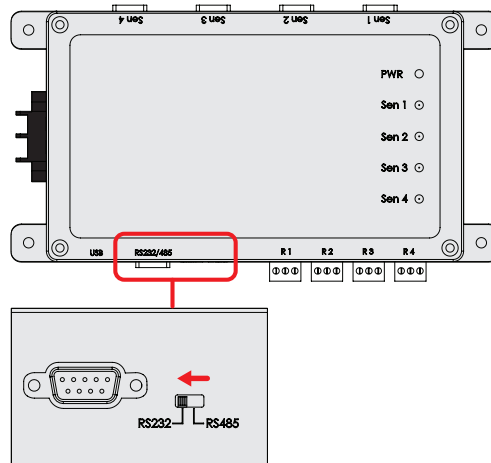

Figure 15. Changing control box output to support RS232 connection

6. Connect the cable from RS232 serial output on the control box to ES-U-3001-M converter as in Figure 15.

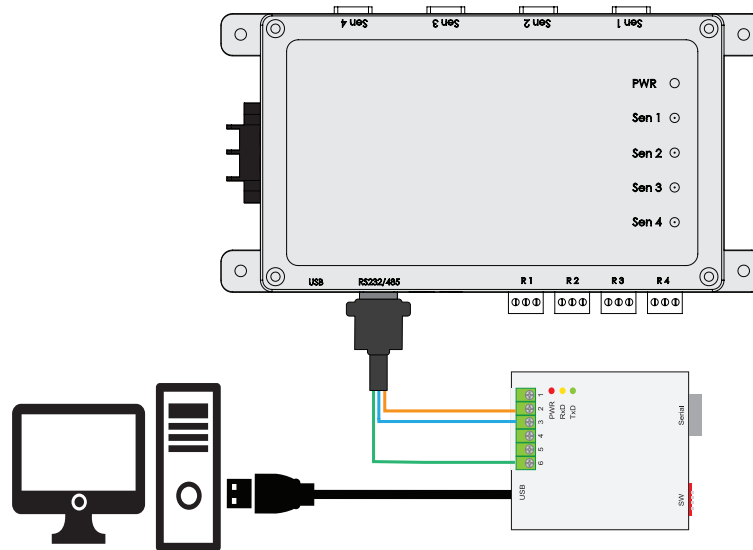
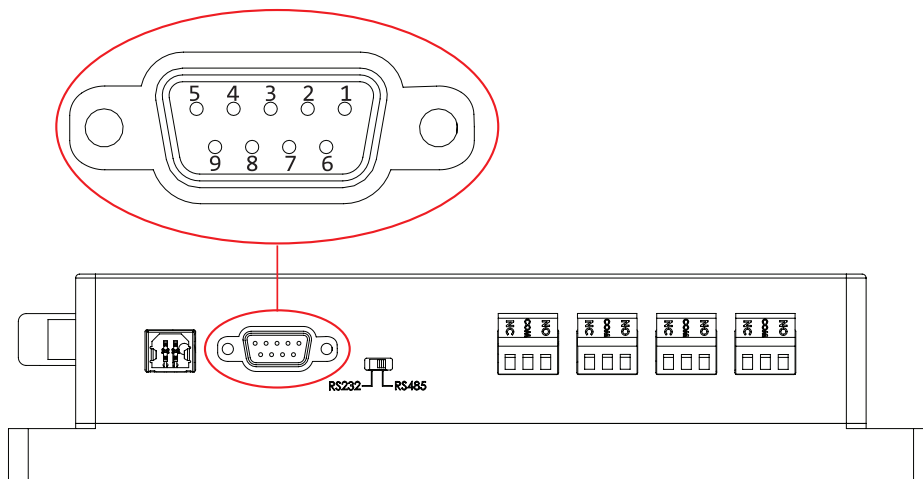

Figure 16. Diagram RS232 Serial connection through control box using and ES-U-3001-M serial converter to PC

7. The connection wiring pinout of the control box RS232 serial output is illustrated in Figure 17.



Pin No.	Description
1	NC
2	RS485 - A (Non-inverting Receiver Input/Tx+)
3	RS485 - B (Inverting Receiver Input/Tx-)
4	RS485 - Z (Inverting Driver Output)/Rx-
5	RS485 - Y (Noninverting Driver Output / Rx+)
6	GND
7	NC
8	RS232 - Receiver Input (Rx)
9	RS232 - Transmitter Output (Tx)

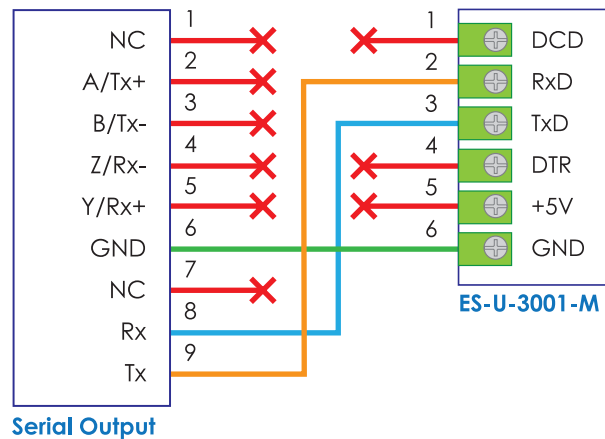

Figure 17. The connection pinout of RS232 Serial Output with ES-U-3001-M converter in RS232 mode

8. The configuration is then completed. The configuration is then completed. Users can obtain data through PC Sync software please refer to "4. Operation", using Digi-Pas DLL refer to "5.2 . DLL for Serial Communication Protocol Through Digi-Pas Control Box" or direct programming refer to "7. Serial Communication Protocol for Control Box"

3.2. Configuration of Single Tilt Sensor Module without control box

3.2.1. Materials for the Configuration

- 1 × DWL5000XY, DWL5500XY or DWL5800XY tilt sensor module secured with sensor cord
- 1 × RS485 converter (4 wires). In this example, EasySync Converter (Model number: ES-U-3001-M) is used
- 1 × 9V DC Power Source
- 1 × custom cable with DB9 (Female) connector
- Computer/Workstation with PC Sync software installed

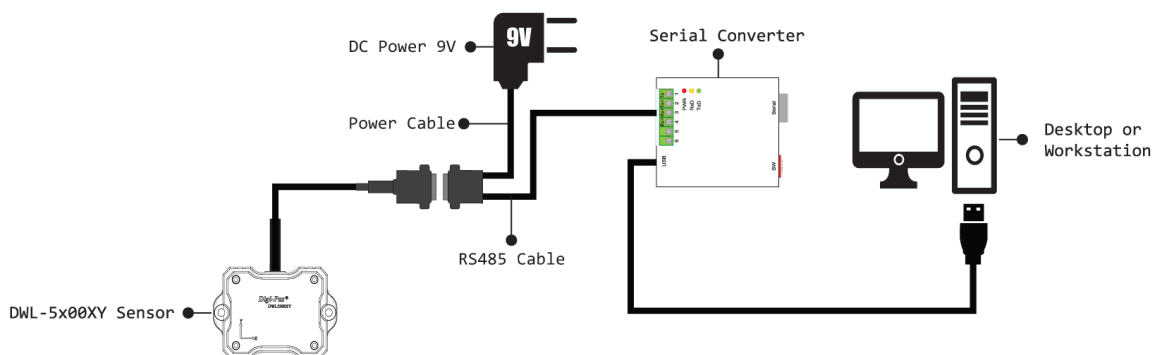

Figure 18. Diagram for Direct Serial connection without control box using custom cable and ES-U-3001-M converter

3.2.2. Configuration Setup Procedure (RS485)

1. Prepare the custom cable. The constructed custom cable and the pinout of the DB9 (Female) connector is shown in Figure 19.

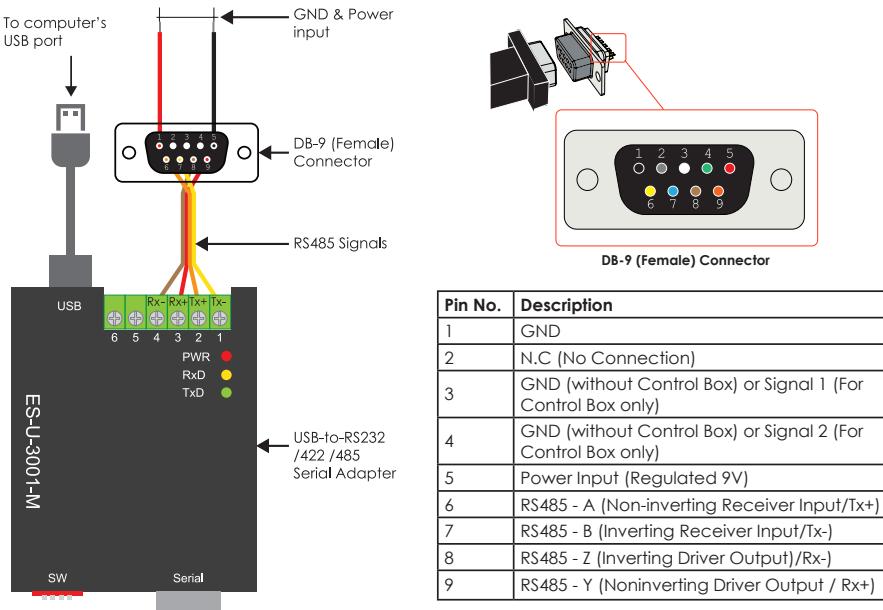

Figure 19. Constructed custom cable and pinout of the DB9 (Female) connector

2. Connect the custom cable with sensor cord and ES-U-3001-M converter as in following connection pinout illustrated in Figure 20.

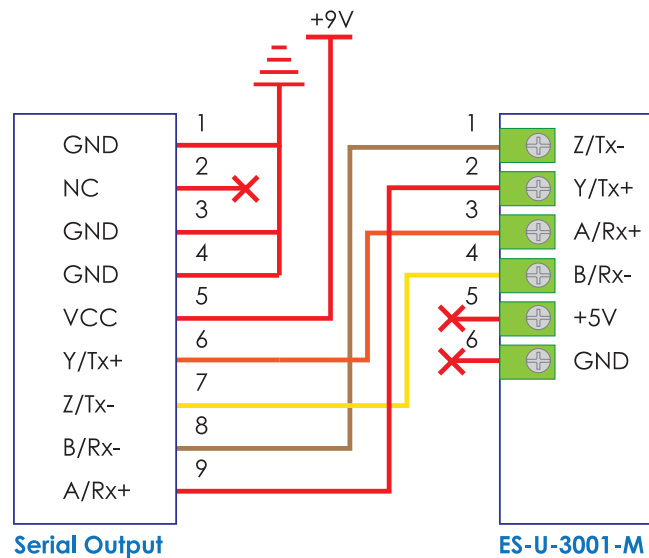

Figure 20. Connection custom cable and ES-U-3001-M converter

3. The configuration is then completed. Users can obtain data through PC Sync software please refer to "4. Operation", using Digi-Pas DLL refer to "5.2 DLL for Serial Communication Protocol Direct to Sensor" or direct programming refer to "6. RS485/232 Serial Communication Protocol for Single DWL5x00XY Tilt Sensor"

4. Operation

4.1. Installation of the DWL5x00XY PC Sync Software

1. DWL5000XY, DWL5500XY or DWL5800XY PC Sync Software Basic Edition CD comes together with the tilt sensor module package. Insert the PC Sync Software CD to the PC, auto-run screen appears as in Figure 21. Click on “Windows OS 64 Bit Install Only” button to start the installation. Alternatively, DWL5000XY or DWL5500XY PC Sync Software Basic Edition can be downloaded from <https://www.digipas.com/support/firmware.php>.

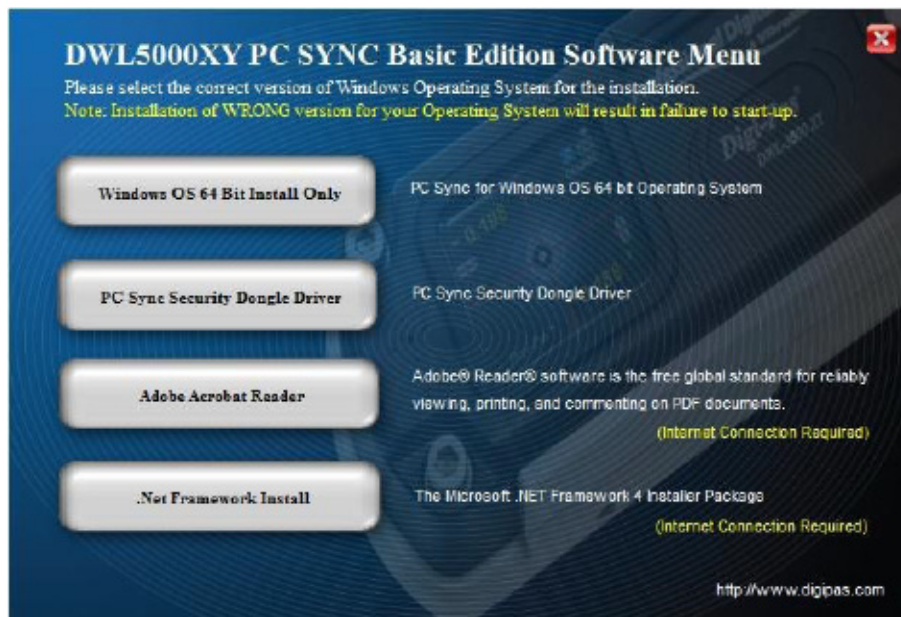

Figure 21. Interface of the software installation page

2. Follow the instructions on the screen, once the installation is completed, shortcut of the DWL5x00XY icon will be appeared in desktop as shown in Figure 22. The PC is now ready to connect with the tilt sensor module or control box.



Figure 22. Shortcut of the DWL5x00XY PC SYNC

4.2. Operation of Single Tilt Sensor Module with Converter

1. Assuming steps stated in 3.1 Configuration of Single Tilt Sensor Module with Converter and 4.1 Installation of the DWL5x00XY PC Sync Software have been done in this stage. Open PC SYNC software and select RS485 from the drop down menu as shown in Figure 23.

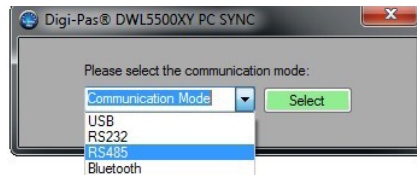

Figure 23. Shortcut of the DWL5x00XY PC SYNC

2. Next, click “No” button as in Figure 24.

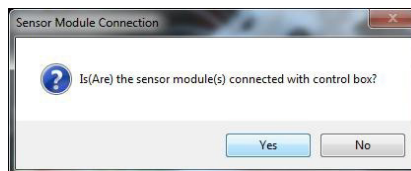

Figure 24. Select RS485 from the drop down menu

3. Select the COM port

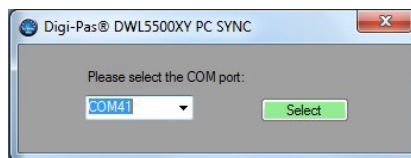

Figure 25. COM port selection

4. Screen as illustrated in Figure 26 appears. The feature icons are enabled and ready for selection (e.g. Single Angle Meter, Dual Angle Meter...). Following is an example when Single Angle Meter feature icon is clicked.

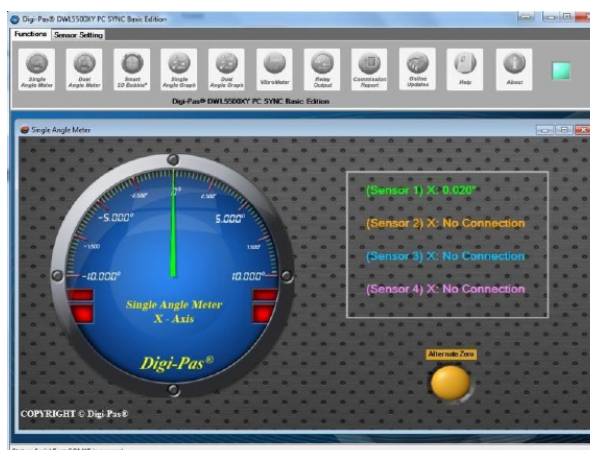

Figure 26. Interface of the PC SYNC software with Single Angle Meter feature

4.3. Operation of Sensor Module(s) with Control Box

1. Assuming steps stated in 3.2 Configuration of Sensor Module(s) with Control Box and 4.1 Installation of the DWL5x000XY PC Sync Software have been done in this stage. Open PC SYNC software and select the desired mode from the drop down menu as shown in Figure 27. In this example, RS485 is selected.

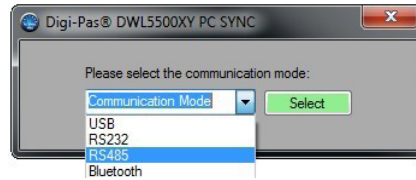

Figure 27. Select mode from the drop down menu

2. Next, click “Yes” button as in Figure 28.

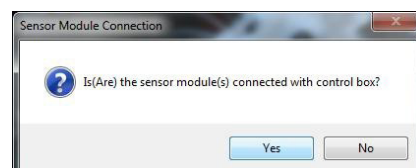

Figure 28. Select RS485 from the drop down menu

3. Select the COM port or Discover Bluetooth Device if connection via Bluetooth

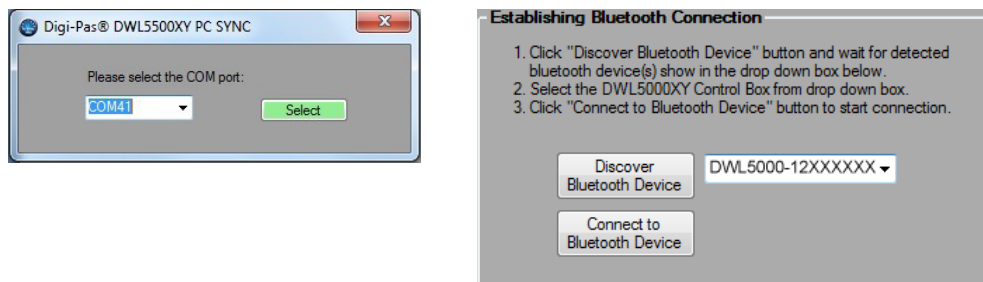

Figure 29. COM port or Bluetooth Discovery

4. Screen as illustrated in Figure 30 appears. The feature icons are enabled and ready for selection (e.g. Single Angle Meter, Dual Angle Meter...). Following is an example when Single Angle Meter feature icon is clicked.

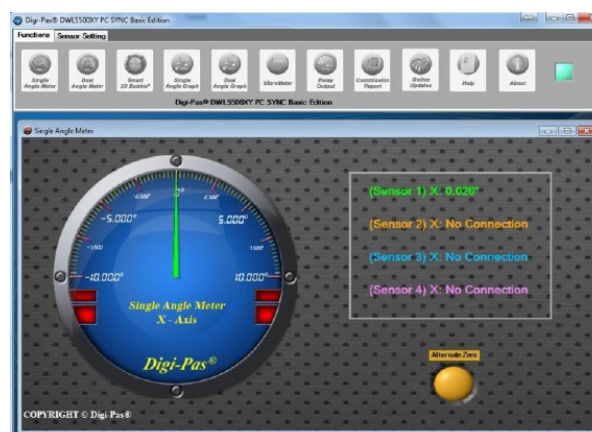

Figure 30. Interface of the PC SYNC software with Single Angle Meter feature

4.4. Direction of the Single-Axis and Dual-Axis Measured Angle

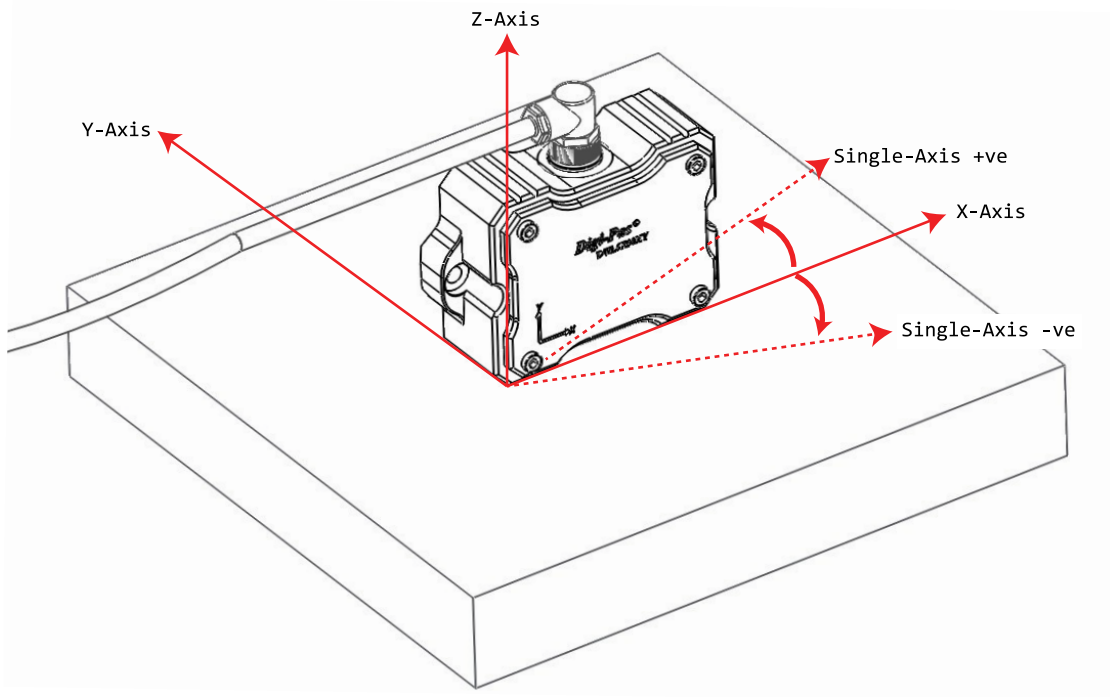

Figure 31. The direction (+ve or - ve) of the Single-Axis measured angle value is indicated as in figure above.

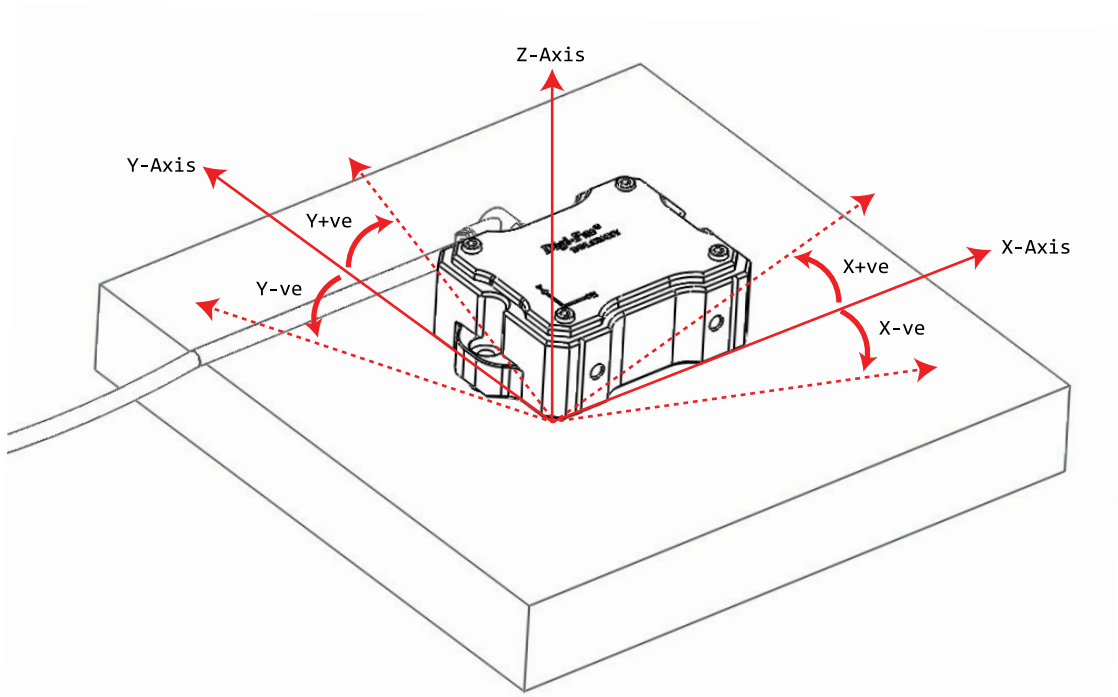

Figure 32. The direction (+ve or - ve) of the Dual-Axis measured angle value is indicated as in figure above.

5. Dynamic-Link Libraries For DWL5x00XY Tilt Sensor Module Notes

5.1. Introduction

The dynamic-link library (DWL5000XYLibrary.dll & DWL5500XYLibrary.dll) is created for users who wish to develop the application software themselves in order to read out the sensor / vibro value from the Directly Sensor or through DWL5000XY control box. This dynamic link library is developed by using Microsoft Visual Studio 2019.

This application note explains the functions and macros contained in the dynamic link library. Examples of use are also provided.

User who wish to use DWL5000XYLibrary.dll or DWL5500XYLibrary.dll need to include this library to their reference folder under the application project.

5.1.1. Absolute Level in Single & Dual Axis Mode Calculation

To set the device in absolute level measurement, please follow the following calculation formula:

Absolute offset data = (Front Measurement Position Value + Back Measurement Position Value) / 2

Absolute Level mode measurement = Measurement data - absolute offset data

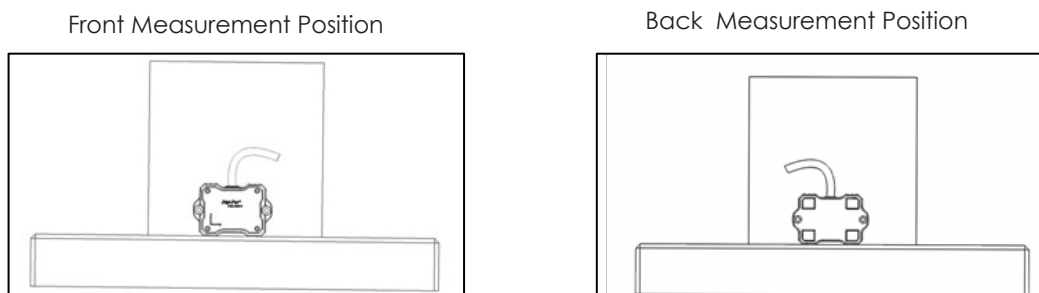

Example sensor position illustration in absolute offset setup for single-axis mode

Example:

Front Measurement Position Value	= 1.5 °
Back Measurement Position Value	= - 2.3 °
Absolute offset data	= (Front Measurement Position Value + Back Measurement Position Value) / 2
Absolute offset data	= (1.5 ° + (- 2.3°)) / 2
	= - 0.4 °
Absolute Level mode measurement	= Measurement data - Absolute offset data
	= 1.5 °- (-0.4 °)
	= 1.9°

Note:

- Absolute offset data required to perform on predetermined measurement surfaces.

- Ensure the device front position measurement & back position measurement are align in the same position with perfect 180° rotation.
- For Dual Axis absolute level offset calculations, the X & Y-Axis require to calculate separately as the offset value for both axis could be different.

5.2. DLL for Serial Communication Protocol Direct to Sensor

This chapter contains Dynamic Link Library functions to configure the serial communication, mode selection, sensor connection status, and reading the angle / vibro value direct from the sensor.

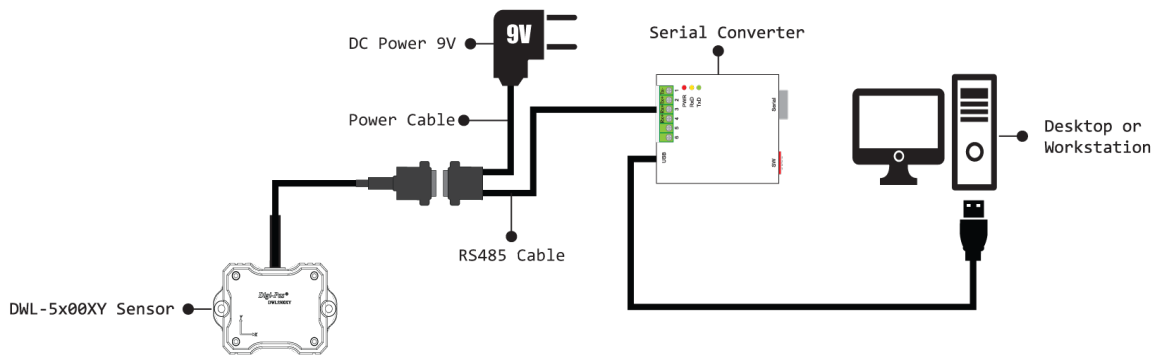

Figure 33. Connecting sensor through Serial Converter

5.2.1. Using the DWL5000XY Dynamic Link Library

This function is only for the use of DWL-5000XY Sensor Module.

5.2.1.1. DWL5000XYLibrary.SerialComm.Serial_Initialization

Description: Initializes and configures the serial communication interface for connecting to the device.

```
public static bool Serial_Initialization(string PortName);
```

Syntax: bool Serial_Initialization(string portName)

Arguments:

Name	Type	Description
portName	string	Name of the COM port to connect to (for example, "COM15").

Return Value: True - Serial initialization successfully

False - Fault occurred during serial initialization

Remarks: The serial communication interface is initialized with the following settings:

- BaudRate : 115200
- Parity : None
- DataBits : 8
- StopBits : One
- FlowControl: None

Code Example: `bool result = DWL4200XYLibrary.SerialComm.Serial_Initialization("COM15");`

5.2.1.2.DWL5000XYLibrary.SerialComm.Mode_Direct

Description: Sends a direct mode command to a specific sensor module with raw parameter bytes.

Syntax: `void Mode_Direct(int sensor,int mode,int data2,int data3, int data4, int data5, int data6)`

Arguments: Mode The mode selection.
data1~data5 Parameters to pass to the selected mode.

Return Value: None

Remarks:

Name	Type	Description
Sensor	Int	Target sensor module index (1-4).
mode	int	Mode command identifier.
data2	int	Mode-specific parameter byte 1.
data3	int	Mode-specific parameter byte 2.
data4	int	Mode-specific parameter byte 3.
data5	int	Mode-specific parameter byte 4.
data6	int	Mode-specific parameter byte 5.

Code Example:

```
Sensor Connection : DWL5000XYLibrary.SerialComm.Mode_Direct(0x01, 0x55, 0, 0, 0, 0,
Status           0);
Single Axis Mode  : DWL5000XYLibrary.SerialComm.Mode_Direct(0x01, 0x01, 0, 0, 0, 0,
                   0);
Dual Axis Mode    : DWL5000XYLibrary.SerialComm.Mode_Direct(0x01, 0x02, 0, 0, 0, 0,
                   0);
Vibro Mode        : DWL5000XYLibrary.SerialComm.Mode_Direct(0x01, 0x03, 0, 0, 0, 0,
                   0);
```

5.2.1.3.DWL5000XYLibrary.SerialComm.Stand

Description: This function reads the device position is in Single Axis mode or Dual Axis mode.

Prototype: `int Stand(int sensor_number)`

Arguments:

Name	Type	Description
sensor_number	int	Sensor Module index (1-4)

Return Value: 1 - Device is in Single Axis Mode
2 - Device is in Dual Axis Mode

Code Example: `int position = DWL5000XYLibrary.SerialComm.Stand(1);`

5.2.1.4.DWL5000XYLibrary.SerialComm.Sensor_Connection_Status

Description: Checks whether the specified sensor module is currently connected.

Syntax: int Sensor_Connection_Status(int sensor_number)

Arguments:

Name	Type	Description
sensor_number	int	The target sensor module number (1-4).

Return Value: Returns the relative X-axis measurement (current X minus alternate zero reference).

Remarks:

- This function returns the connection status of the specified sensor module.
- It is applicable when using a Control Box configuration that supports multiple sensor modules.
- Use Mode_Direct(0x01, 0x55, 0, 0x00, 0, 0) to measurement mode.

Code Example:

```
// request sensor status
DWL5000XYLibrary.SerialComm.Mode_direct(0x01, 0x55, 0, 0, 0, 0);
// Read sensor status
int isConnected = DWL5000XYLibrary.SerialComm.Sensor_Connection_Status(1);
```

5.2.1.5.DWL5000XYLibrary.SerialComm.Dual_X_Value

Description: Reads the X-axis measurement value.

Syntax: double Dual_X_Value (int sensor_number)

Arguments:

Name	Type	Description
sensor_number	int	The target sensor module number (1-4).

Return Value: Returns the current X-axis measurement value reported by the sensor.

Remarks:

- Before calling this function, the device must be configured for Dual Axis Measurement mode.
- Use Mode_Direct(0x01, 0x02, 0, 0x00, 0, 0) to enable dual axis measurement mode.

Code Example:

```
// Enable Dual Axis measurement mode
DWL5000XYLibrary.SerialComm.Mode_Direct(0x01, 0x02, 0, 0x00, 0, 0);
// Read X axis value
double x = DWL5000XYLibrary.SerialComm.Dual_X_Value(1);
```

5.2.1.6.DWL5000XYLibrary.SerialComm.Dual_Y_Value

Description: Reads the Y-axis measurement value.

Syntax: double Dual_Y_Value(int sensor_number)

Arguments:

Name	Type	Description
sensor_number	int	Sensor Module index (1-4)

Return Value: Returns the current Y-axis measurement value reported by the sensor.

Remarks:

- Before calling this function, the device must be configured for Dual Axis Measurement mode.
- Use Mode_Direct(0x01, 0x02, 0, 0x00, 0, 0) to enable dual axis measurement mode.

Code Example:

```
// Enable Dual Axis measurement mode
DWL5000XYLibrary.SerialComm.Mode_Direct(0x01, 0x02, 0,
0x00, 0, 0);
// Read Y axis value
double y = DWL5000XYLibrary.SerialComm.Dual_Y_Value(1);
```

5.2.1.7.DWL5000XYLibrary.SerialComm.Single_Value

Description: Reads the Single axis measurement value.

Syntax: double Single_Value(int sensor_number)

Arguments:

Name	Type	Description
sensor_number	int	Sensor Module index (1-4)

Return Value: Returns the current X-Axis measurement value reported by the sensor.

Remarks:

- Before calling this function, the device must be configured for Single Axis Measurement mode.
- Use Mode_Direct(0x01, 0x01, 0, 0x00, 0, 0) to enable single axis measurement mode.

Code Example:

```
// Enable single Axis measurement mode
DWL5000XYLibrary.SerialComm.Mode_Direct(0x01, 0x01, 0,
0x00, 0, 0);
// Read x axis value
double single_value = DWL5000XYLibrary.SerialComm.single_value(1);
```

5.2.1.8.DWL5000XYLibrary.SerialComm.Vibro_Value

Description: This function reads the vibro value.

Syntax: double Vibro_Value(int sensor_number)

Arguments:

Name	Type	Description
sensor_number	int	Sensor module index (1-4)

Return Value: Returns the current vibration measurement value reported by the sensor.

- Remarks:**
- Before calling this function, the device must be configured for vibration measurement mode.
 - Use Mode_Direct(0x01, 0x03, 0, 0x00, 0, 0) to enable vibro measurement mode.

Code Example:

```
// Enable vibration measurement mode
DWL5000XYLibrary.SerialComm.Mode_Direct(0x01, 0x03, 0,
0x00, 0, 0);
// Read vibration value
double vibro = DWL5000XYLibrary.SerialComm.Vibro_Val-
ue(1);
```

5.2.1.9.DWL5000XYLibrary.SerialComm.Dual_Alt_Zero_Set

Description: Defines the current dual-axis (X and Y) measurements as the alternate zero reference for a specified sensor.

Syntax: void Dual_Alt_Zero_Set(int sensorNumber)

Arguments:

Name	Type	Description
sensorNumber	int	The target sensor module number (1-4).

Return Value: None

- Remarks:**
- This function captures the current X-axis and Y-axis measurements and stores them internally as the alternate zero reference.
 - When alternate zero is enabled, subsequent dual-axis readings are reported as relative values (delta) from this reference.

Code Example: DWL5000XYLibrary.SerialComm.Dual_Alt_Zero_Set(1);

5.2.1.10. DWL5000XYLibrary.SerialComm.Dual_Alt_Zero_Clear

Description: Disables alternate zero and clears the stored reference value.

Syntax: void Dual_Alt_Zero_Clear(int sensorNumber)

Arguments:

Name	Type	Description
sensorNumber	int	The target sensor module number (1-4).

Return Value: None.

Remarks:

- Clears the alternate zero reference and restores normal absolute single-axis measurement output.

Code Example: DWL5000XYLibrary.SerialComm.Single_Alt_Zero_clear(1);

5.2.1.11. DWL5000XYLibrary.SerialComm.Dual_x_Alt_Zero_Value

Description: Reads the X-axis measurement relative to the alternate zero reference.

Syntax: double Dual_x_Alt_Zero_Value(int sensorNumber)

Arguments:

Name	Type	Description
sensorNumber	int	The target sensor module number (1-4).

Return Value: Returns the relative X-axis measurement (current X minus alternate zero reference).

Remarks:

- If alternate zero is enabled, this function returns the delta between the live X-axis measurement and the stored reference value.
- If alternate zero is disabled, the absolute X-axis measurement is returned.

Code Example: double x = DWL5000XYLibrary.SerialComm.Dual_x_Alt_Zero_Value(1);

5.2.1.12. DWL5000XYLibrary.SerialComm.Dual_y_Alt_Zero_Value

Description: Reads the Y-axis measurement relative to the alternate zero reference.

Syntax: double Dual_y_Alt_Zero_Value(int sensorNumber)

Arguments:

Name	Type	Description
sensorNumber	int	The target sensor module number (1-4).

Return Value: Returns the relative Y-axis measurement (current Y minus alternate zero reference).

- Remarks:**
- If alternate zero is enabled, this function returns the delta between the live Y-axis measurement and the stored reference value.
 - If alternate zero is disabled, the absolute Y-axis measurement is returned.

Code Example: `double y = DWL5000XYLibrary.SerialComm.Dual_y_Alt_Zero_Value(1);`

5.2.1.13. DWL5000XYLibrary.SerialComm.Single_Alt_Zero_Set

Description: Defines the current single-axis measurement as the alternate zero reference for a specified sensor.

Syntax: `void Single_Alt_Zero_Set(int sensor_number)`

Arguments:

Name	Type	Description
sensor_number	Int	The target sensor module number (1-4).

Return Value: None

- Remarks:**
- This function stores the current single-axis reading as a reference inside the DLL.
 - The alternate zero reference remains active until `Single_Alt_Zero_Clear()` is called.

Code Example: `DWL5000XYLibrary.SerialComm.Single_Alt_Zero_Set(1);`

5.2.1.14. DWL5000XYLibrary.SerialComm.Single_Alt_Zero_clear

Description: Disables alternate zero and clears the stored reference value.

Syntax: `void Single_Alt_Zero_Clear(int sensorNumber)`

Arguments:

Name	Type	Description
sensorNumber	int	The target sensor module number (1-4).

Return Value: None.

- Remarks:**
- Clears the alternate zero reference and restores normal absolute single-axis measurement output.

Code Example: `DWL5000XYLibrary.SerialComm.Single_Alt_Zero_clear(1);`

5.2.1.15. DWL5000XYLibrary.SerialComm.Single_Alt_Zero_Value

Description: This function reads the alternate zero (Single Axis) reference value.

Syntax: `double Single_Alt_Zero_Value(int sensorNumber)`

Arguments: Name Type Description

sensorNumber int The target sensor module number (1-4).

Return Value: Alternate Zero (Single Axis) reference value.

Remarks:

- This function stores the current single-axis reading as a reference inside the DLL.
- The alternate zero reference remains active until Single_Alt_Zero_Clear() is called.

Code Example: double value = DWL5000XYLibrary.SerialComm.Single_Alt_Zero_Value(1);

5.2.2. Using the DWL5500XY Dynamic Link Library

This function is only for use DWL-5500XY Sensor Module.

5.2.2.1.DWL5500XYLibrary.SerialComm.Serial_Initialization

Description: Initializes and configures the serial communication interface for connecting to the device.

```
public static bool Serial_Initialization(string PortName);
```

Syntax: bool Serial_Initialization(string portName)

Arguments:

Name	Type	Description
portName	string	Name of the COM port to connect to (for example, "COM15").

Return Value: True - Serial initialization successfully
False - Fault occurred during serial initialization

Remarks: The serial communication interface is initialized with the following settings:

- BaudRate : 115200
- Parity : None
- DataBits : 8
- StopBits: One
- FlowControl: None

Code Example: bool result = DWL5500XYLibrary.SerialComm.Serial_Initialization("COM15");

5.2.2.2.DWL5500XYLibrary.SerialComm.Mode_Direct

Description: Sends a direct mode command to a specific sensor module with raw parameter bytes.

Syntax: void Mode_Direct(int sensor,int mode,int data2,int data3, int data4, int data5, int data6)

Arguments: Mode The mode selection.
data1~data5 Parameters to pass to the selected mode.

Return Value: None

Remarks:	Name	Type	Description
	Sensor	Int	Target sensor module index (1-4).
	mode	int	Mode command identifier.
	data2	int	Mode-specific parameter byte 1.
	data3	int	Mode-specific parameter byte 2.
	data4	int	Mode-specific parameter byte 3.
	data5	int	Mode-specific parameter byte 4.
	data6	int	Mode-specific parameter byte 5.

Code Example:

```

Sensor Connection : DWL5500XYLibrary.SerialComm.Mode_Direct(0x01, 0x55, 0, 0, 0, 0,
Status           0);
Single Axis Mode  : DWL5500XYLibrary.SerialComm.Mode_Direct(0x01, 0x01, 0, 0, 0, 0,
0);
Dual Axis Mode    : DWL5500XYLibrary.SerialComm.Mode_Direct(0x01, 0x02, 0, 0, 0, 0,
0);
Vibro Mode        : DWL5500XYLibrary.SerialComm.Mode_Direct(0x01, 0x03, 0, 0, 0, 0,
0);
    
```

5.2.2.3.DWL5500XYLibrary.SerialComm.set_location

Description: This function configures the sensor location. User can refer to APPENDIX 2: Country and City Index for the list.

Syntax public static void set_location (int country_index, int city country_index)

Arguments: country index & city index number.

Return Value: None

Code Example: DWL5500XYLibrary.SerialComm.set_location(0x05, 0x01);

5.2.2.4.DWL5500XYLibrary.SerialComm.Stand

Description: This function reads the device position is in Single Axis mode or Dual Axis mode.

Prototype: int Stand(int sensor_number)

Arguments:	Name	Type	Description
	sensor_number	int	Sensor Module index (1-4)

Return Value: 1 - Device is in Single Axis Mode

2 - Device is in Dual Axis Mode

Code Example: int position = DWL5500XYLibrary.SerialComm.Stand(1);

5.2.2.5.DWL5500XYLibrary.SerialComm.Sensor_Connection_Status

Description: Checks whether the specified sensor module is currently connected.

Syntax: int Sensor_Connection_Status(int sensor_number)

Arguments:

Name	Type	Description
sensor_number	int	The target sensor module number (1-4).

Return Value: 0 - Sensor module is not connected

1 - Sensor module is connected

- Remarks:**
- This function returns the connection status of the specified sensor module.
 - It is applicable when using a Control Box configuration that supports multiple sensor modules.
 - Use Mode_Direct(0x01, 0x55, 0, 0x00, 0, 0) to enable sensor status mode.

Code Example:

```
// request sensor status
DWL5500XYLibrary.SerialComm.Mode_direct(0x01, 0x55, 0, 0, 0, 0);
// Read sensor status
int isConnected = DWL5500XYLibrary.SerialComm.Sensor_Connection_Status(1);
```

5.2.2.6.DWL5500XYLibrary.SerialComm.Dual_X_Value

Description: Reads the X-axis measurement value.

Syntax: double Dual_X_Value (int sensor_number)

Arguments:

Name	Type	Description
sensor_number	int	The target sensor module number (1-4).

Return Value: Returns the current X-axis measurement value reported by the sensor.

- Remarks:**
- Before calling this function, the device must be configured for Dual Axis Measurement mode.
 - Use Mode_Direct(0x01, 0x02, 0, 0x00, 0, 0) to enable dual axis measurement mode.

Code Example:

```
// Enable Dual Axis measurement mode
DWL5500XYLibrary.SerialComm.Mode_Direct(0x01, 0x02, 0, 0x00, 0, 0);
// Read X axis value
double x = DWL5500XYLibrary.SerialComm.Dual_X_Value(1);
```

5.2.2.7.DWL5500XYLibrary.SerialComm.Dual_Y_Value

Description: Reads the Y-axis measurement value.

Syntax: double Dual_Y_Value(int sensor_number)

Arguments:

Name	Type	Description
sensor_number	int	Sensor Module index (1-4)

Return Value: Returns the current Y-axis measurement value reported by the sensor.

Remarks:

- Before calling this function, the device must be configured for Dual Axis Measurement mode.
- Use Mode_Direct(0x01, 0x02, 0, 0x00, 0, 0) to enable dual axis measurement mode.

Code Example:

```
// Enable Dual Axis measurement mode
DWL5500XYLibrary.SerialComm.Mode_Direct(0x01, 0x02, 0,
0x00, 0, 0);
// Read Y axis value
double y = DWL5500XYLibrary.SerialComm.Dual_Y_Value(1);
```

5.2.2.8.DWL5500XYLibrary.SerialComm.Single_Value

Description: Reads the Single axis measurement value.

Syntax: double Single_Value(int sensor_number)

Arguments:

Name	Type	Description
sensor_number	int	Sensor Module index (1-4)

Return Value: Returns the current X-Axis measurement value reported by the sensor.

Remarks:

- Before calling this function, the device must be configured for Single Axis Measurement mode.
- Use Mode_Direct(0x01, 0x01, 0, 0x00, 0, 0) to enable single axis measurement mode.

Code Example:

```
// Enable single Axis measurement mode
DWL5500XYLibrary.SerialComm.Mode_Direct(0x01, 0x01, 0,
0x00, 0, 0);
// Read x axis value
double single_value = DWL5500XYLibrary.SerialComm.single_value(1);
```

5.2.2.9. DWL5500XYLibrary.SerialComm.Vibro_Value

Description: This function reads the vibro value.

Syntax: double Vibro_Value(int sensor_number)

Arguments:	Name	Type	Description
	sensor_number	int	Sensor module index (1-4)

Return Value: Returns the current vibration measurement value reported by the sensor.

- Remarks:**
- Before calling this function, the device must be configured for vibration measurement mode.
 - Use Mode_Direct(0x01, 0x03, 0, 0x00, 0, 0) to enable vibro measurement mode.

Code Example:

```
// Enable vibration measurement mode
DWL5500XYLibrary.SerialComm.Mode_Direct(0x01, 0x03, 0, 0x00, 0, 0);
// Read vibration value
double vibro = DWL5500XYLibrary.SerialComm.Vibro_Value(1);
```

5.2.2.10. DWL5500XYLibrary.SerialComm.Single_Alt_Zero_Set

Description: Defines the current single-axis measurement as the alternate zero reference for a specified sensor.

Syntax: void Single_Alt_Zero_Set(int sensor_number)

Arguments:	Name	Type	Description
	sensorNumber	Int	The target sensor module number (1-4).

Return Value: None

- Remarks:**
- This function stores the current single-axis reading as a reference inside the DLL.
 - The alternate zero reference remains active until Single_Alt_Zero_Clear() is called.

Code Example:

```
double value = DWL5500XYLibrary.SerialComm.Single_Alt_Zero_Set(1);
```

5.2.2.11. DWL5500XYLibrary.SerialComm.Single_Alt_Zero_clear

Description: Disables alternate zero and clears the stored reference value.

Syntax: void Single_Alt_Zero_Clear(int sensorNumber)

Arguments:	Name	Type	Description
	sensorNumber	int	The target sensor module number (1-4).

Return Value: None.

Remarks:

- Clears the alternate zero reference and restores normal absolute single-axis measurement output.

Code Example: `DWL5500XYLibrary.SerialComm.Single_Alt_Zero_clear(1);`

5.2.2.12. DWL5500XYLibrary.SerialComm.Single_Alt_Zero_Value

Description: This function reads the alternate zero (Single Axis) reference value.

Syntax: `public static double Single_Alt_Zero_Value(int sensor_number)`

Arguments:

Name	Type	Description
sensorNumber	int	The target sensor module number (1-4).

Return Value: Alternate Zero (Single Axis) reference value.

Remarks:

- This function stores the current single-axis reading as a reference inside the DLL.
- The alternate zero reference remains active until `Single_Alt_Zero_Clear()` is called.

Code Example: `double value = DWL5500XYLibrary.SerialComm.Single_Alt_Zero_Value(1);`

5.2.2.13. DWL5500XYLibrary.SerialComm.Dual_Alt_Zero_Set

Description: Defines the current dual-axis (X and Y) measurements as the alternate zero reference for a specified sensor.

Syntax: `void Dual_Alt_Zero_Set(int sensorNumber)`

Arguments:

Name	Type	Description
sensorNumber	int	The target sensor module number (1-4).

Return Value: None

Remarks:

- This function captures the current X-axis and Y-axis measurements and stores them internally as the alternate zero reference.
- When alternate zero is enabled, subsequent dual-axis readings are reported as relative values (delta) from this reference.

Code Example: `DWL5500XYLibrary.SerialComm.Dual_Alt_Zero_Set(1);`

5.2.2.14. DWL5500XYLibrary.SerialComm.Dual_Alt_Zero_Clear

Description: Clears the stored X and Y alternate zero references and restores normal absolute dual-axis measurement output.

Syntax: void Dual_Alt_Zero_Clear(int sensorNumber)

Arguments:

Name	Type	Description
sensorNumber	int	The target sensor module number (1-4).

Return Value: None

Remarks:

- Clears the alternate zero reference and restores normal absolute single-axis measurement output.

Code Example: DWL4500XYLibrary.SerialComm.Dual_Alt_Zero_Clear(1);

5.2.2.15. DWL5500XYLibrary.SerialComm.Dual_x_Alt_Zero_Value

Description: Reads the X-axis measurement relative to the alternate zero reference.

Syntax: double Dual_x_Alt_Zero_Value(int sensorNumber)

Arguments:

Name	Type	Description
sensorNumber	int	The target sensor module number (1-4).

Return Value: Returns the relative X-axis measurement (current X minus alternate zero reference).

Remarks:

- If alternate zero is enabled, this function returns the delta between the live X-axis measurement and the stored reference value.
- If alternate zero is disabled, the absolute X-axis measurement is returned.

Code Example: double x = DWL5500XYLibrary.SerialComm.Dual_x_Alt_Zero_Value(1);

5.2.2.16. DWL5500XYLibrary.SerialComm.Dual_y_Alt_Zero_Value

Description: Reads the Y-axis measurement relative to the alternate zero reference.

Syntax: double Dual_y_Alt_Zero_Value(int sensorNumber)

Arguments:

Name	Type	Description
sensorNumber	int	The target sensor module number (1-4).

Return Value: Returns the relative Y-axis measurement (current Y minus alternate zero reference).

- Remarks:**
- If alternate zero is enabled, this function returns the delta between the live Y-axis measurement and the stored reference value.
 - If alternate zero is disabled, the absolute Y-axis measurement is returned.

Code Example: `double y = SerialComm.Dual_y_Alt_Zero_Value(1);`

5.3. DLL for Serial Communication Protocol Through Digi-Pas Control Box

This chapter contains Dynamic Link Library functions to configure the serial communication, mode selection, sensor connection status, and reading the angle / vibro value through the DWL5000 control box.

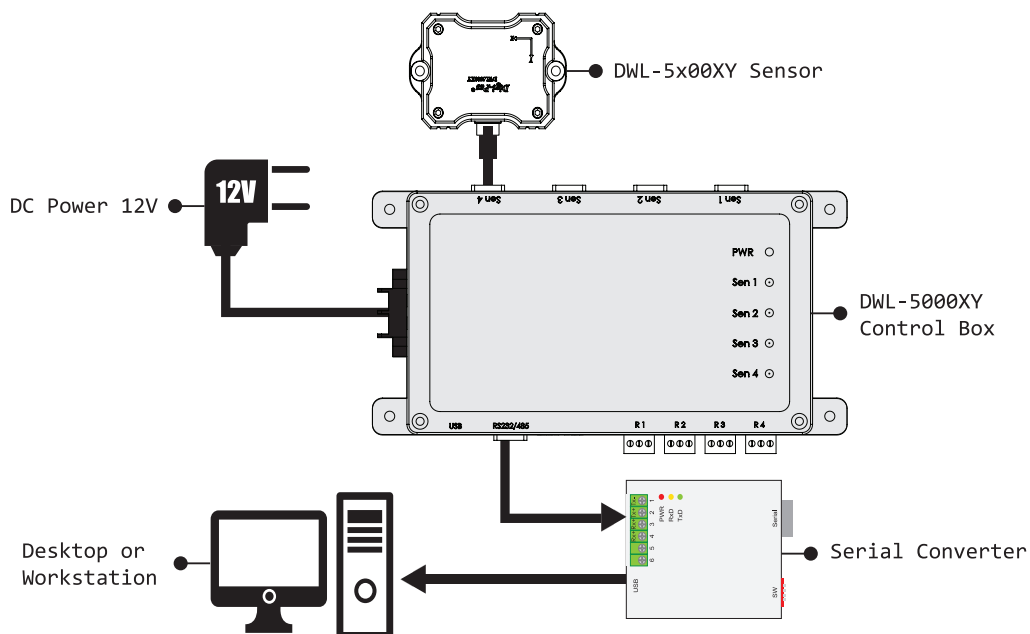

Figure 34. Connecting sensor through Digi-Pas Control box

5.3.1. Using the DWL5000XY Dynamic Link Library

This function is only for the use of DWL-5000XY Sensor Module with Digi-Pas Control Box.

5.3.1.1. DWL5000XYLibrary.SerialComm.Serial_Initialization

Description: Initializes and configures the serial communication interface for connecting to the device.

```
public static bool Serial_Initialization(string PortName);
```

Syntax: `bool Serial_Initialization(string portName)`

Arguments:

Name	Type	Description
portName	string	Name of the COM port to connect to (for example, "COM15").

Return Value: True - Serial initialization successfully
 False - Fault occurred during serial initialization

Remarks: The serial communication interface is initialized with the following settings:

- BaudRate : 115200
- Parity : None
- DataBits : 8
- StopBits : One
- FlowControl: None

Code Example: `bool result = DWL5000XYLibrary.SerialComm.Serial_Initialization("COM15");`

5.3.1.2.DWL5000XYLibrary.SerialComm.Mode

Description: Sends a direct mode command to a specific sensor module with raw parameter bytes.

Syntax: `void Mode(int sensor,int mode,int data2,int data3, int data4, int data5, int data6)`

Arguments: Mode The mode selection.
 data1~data5 Parameters to pass to the selected mode.

Return Value: None

Remarks:

Name	Type	Description
Sensor	Int	Target sensor module index (1-4).
mode	int	Mode command identifier.
data2	int	Mode-specific parameter byte 1.
data3	int	Mode-specific parameter byte 2.
data4	int	Mode-specific parameter byte 3.
data5	int	Mode-specific parameter byte 4.
data6	int	Mode-specific parameter byte 5.

Code Example:

```
Sensor Connection : DWL5000XYLibrary.SerialComm.Mode(0x01, 0x55, 0, 0, 0, 0, 0);
Status
Single Axis Mode : DWL5000XYLibrary.SerialComm.Mode(0x01, 0x01, 0, 0, 0, 0, 0);
Dual Axis Mode : DWL5000XYLibrary.SerialComm.Mode(0x01, 0x02, 0, 0, 0, 0, 0);
Vibro Mode : DWL5000XYLibrary.SerialComm.Mode(0x01, 0x03, 0, 0, 0, 0, 0);
```

5.3.1.3.DWL5000XYLibrary.SerialComm.Stand

Description: Determines whether the specified sensor is operating in Single-Axis mode or Dual-Axis mode.

Syntax: int Stand(int sensorNumber)

Arguments:

Name	Type	Description
sensorNumber	int	Sensor module index (1-4)

Return Value:

1 - Device is operating in Single-Axis mode
 2 - Device is operating in Dual Axis Mode

Code Example: int mode = DWL5000XYLibrary.SerialComm.Stand(1);

5.3.1.4.DWL5000XYLibrary.SerialComm.Sensor_Connection_Status

Description: Checks whether the specified sensor module is currently connected.

Syntax: int Sensor_Connection_Status(int sensor_number)

Arguments:

Name	Type	Description
sensor_number	int	The target sensor module number (1-4).

Return Value:

0 - Sensor module is not connected
 1 - Sensor module is connected

- Remarks:**
- This function returns the connection status of the specified sensor module.
 - It is applicable when using a Control Box configuration that supports multiple sensor modules.
 - Use Mode(0x55, 0, 0, 0, 0, 0) to enable sensor status mode.

Code Example:

```
// request sensor status
DWL5000XYLibrary.SerialComm.Mode(0x55, 0, 0, 0, 0, 0);
// Read sensor Status
int isConnected = DWL4200XYLibrary.SerialComm.Sensor_Connection_Status(1);
```

5.3.1.5.DWL5000XYLibrary.SerialComm.Dual_X_Value

Description: Reads the X-axis measurement value.

Syntax: double Dual_X_Value (int sensor_number)

Arguments:

Name	Type	Description
sensor_number	int	The target sensor module number (1-4).

Return Value: Returns the current X-axis measurement value reported by the sensor.

- Remarks:**
- Before calling this function, the device must be configured for Dual Axis Measurement mode.
 - Use Mode(0x01, 0, 0, 0, 0, 0) to enable dual axis measurement mode.

Code Example:

```
// Enable Dual Axis measurement mode
DWL5000XYLibrary.SerialComm.Mode(0x01, 0, 0, 0, 0, 0);
// Read X axis value
double x = DWL5000XYLibrary.SerialComm.Dual_X_Value(1);
```

5.3.1.6.DWL5000XYLibrary.SerialComm.Dual_Y_Value

Description: Reads the Y-axis measurement value.

Syntax: double Dual_Y_Value(int sensor_number)

Arguments:

Name	Type	Description
sensor_number	int	Sensor Module index (1-4)

Return Value: Returns the current Y-axis measurement value reported by the sensor.

- Remarks:**
- Before calling this function, the device must be configured for Dual Axis Measurement mode.
 - Use Mode(0x02, 0, 0, 0, 0, 0) to enable dual axis measurement mode.

Code Example:

```
// Enable Dual Axis measurement mode
DWL5000XYLibrary.SerialComm.Mode(0x02, 0, 0, 0, 0, 0);
// Read Y axis value
double y = DWL5000XYLibrary.SerialComm.Dual_Y_Value(1);
```

5.3.1.7.DWL5000XYLibrary.SerialComm.Single_Value

Description: Reads the Single axis measurement value.

Syntax: double Single_Value(int sensor_number)

Arguments:

Name	Type	Description
sensor_number	int	Sensor Module index (1-4)

Return Value: Returns the current X-Axis measurement value reported by the sensor.

- Remarks:**
- Before calling this function, the device must be configured for Single Axis Measurement mode.
 - Use Mode(0x01, 0, 0, 0, 0, 0) to enable single axis measurement mode.

Code Example: // Enable single Axis measurement mode
 DWL4200XYLibrary.SerialComm.Mode(0x01, 0, 0, 0, 0, 0);
 // Read x axis value
 double single_value = DWL5000XYLibrary.SerialComm.single_value(1);

5.3.1.8.DWL5000XYLibrary.SerialComm.Vibro_Value

Description: This function reads the vibro value.

Syntax: double Vibro_Value(int sensor_number)

Arguments: Name Type Description
 sensor_number int Sensor module index (1-4)

Return Value: Returns the current vibration measurement value reported by the sensor.

- Remarks:**
- Before calling this function, the device must be configured for vibration measurement mode.
 - Use Mode(0x03, 0, 0, 0, 0, 0) to enable vibro measurement mode.

Code Example: // Enable vibration measurement mode
 DWL5000XYLibrary.SerialComm.Mode(0x03, 0, 0, 0, 0, 0);
 // Read vibration value
 double vibro = DWL5000XYLibrary.SerialComm.Vibro_Value(1);

5.3.1.9.DWL5000XYLibrary.SerialComm.Dual_Alt_Zero_Set

Description: Defines the current dual-axis (X and Y) measurements as the alternate zero reference for a specified sensor.

Syntax: void Dual_Alt_Zero_Set(int sensorNumber)

Arguments:

Name	Type	Description
sensorNumber	int	The target sensor module number (1-4).

Return Value: None

- Remarks:**
- This function captures the current X-axis and Y-axis measurements and stores them internally as the alternate zero reference.
 - When alternate zero is enabled, subsequent dual-axis readings are reported as relative values (delta) from this reference.

Code Example: DWL5000XYLibrary.SerialComm.Dual_Alt_Zero_Set(1);

5.3.1.10. DWL5000XYLibrary.SerialComm.Dual_Alt_Zero_Clear

Description: Disables alternate zero and clears the stored reference value.

Syntax: void Dual_Alt_Zero_Clear(int sensorNumber)

Arguments:

Name	Type	Description
sensorNumber	int	The target sensor module number (1-4).

Return Value: None.

Remarks:

- Clears the alternate zero reference and restores normal absolute single-axis measurement output.

Code Example: DWL5000XYLibrary.SerialComm.Single_Alt_Zero_clear(1);

5.3.1.11. DWL5000XYLibrary.SerialComm.Dual_x_Alt_Zero_Value

Description: Reads the X-axis measurement relative to the alternate zero reference.

Syntax: double Dual_x_Alt_Zero_Value(int sensorNumber)

Arguments:

Name	Type	Description
sensorNumber	int	The target sensor module number (1-4).

Return Value: Returns the relative X-axis measurement (current X minus alternate zero reference).

Remarks:

- If alternate zero is enabled, this function returns the delta between the live X-axis measurement and the stored reference value.
- If alternate zero is disabled, the absolute X-axis measurement is returned.

Code Example: double x = DWL5000XYLibrary.SerialComm.Dual_x_Alt_Zero_Value(1);

5.3.1.12. DWL5000XYLibrary.SerialComm.Dual_y_Alt_Zero_Value

Description: Reads the Y-axis measurement relative to the alternate zero reference.

Syntax: double Dual_y_Alt_Zero_Value(int sensorNumber)

Arguments:

Name	Type	Description
sensorNumber	int	The target sensor module number (1-4).

Return Value: Returns the relative Y-axis measurement (current Y minus alternate zero reference).

- Remarks:**
- If alternate zero is enabled, this function returns the delta between the live Y-axis measurement and the stored reference value.
 - If alternate zero is disabled, the absolute Y-axis measurement is returned.

Code Example: `double y = DWL5000XYLibrary.SerialComm.Dual_y_Alt_Zero_Value(1);`

5.3.1.13. DWL5000XYLibrary.SerialComm.Single_Alt_Zero_Set

Description: Defines the current single-axis measurement as the alternate zero reference for a specified sensor.

Syntax: `void Single_Alt_Zero_Set(int sensor_number)`

Arguments:

Name	Type	Description
sensor_number	Int	The target sensor module number (1-4).

Return Value: None

- Remarks:**
- This function stores the current single-axis reading as a reference inside the DLL.
 - The alternate zero reference remains active until `Single_Alt_Zero_Clear()` is called.

Code Example: `DWL5000XYLibrary.SerialComm.Single_Alt_Zero_Set(1);`

5.3.1.14. DWL5000XYLibrary.SerialComm.Single_Alt_Zero_clear

Description: Disables alternate zero and clears the stored reference value.

Syntax: `void Single_Alt_Zero_Clear(int sensorNumber)`

Arguments:

Name	Type	Description
sensorNumber	int	The target sensor module number (1-4).

Return Value: None.

- Remarks:**
- Clears the alternate zero reference and restores normal absolute single-axis measurement output.

Code Example: `DWL5000XYLibrary.SerialComm.Single_Alt_Zero_clear(1);`

5.3.1.15. DWL5000XYLibrary.SerialComm.Single_Alt_Zero_Value

Description: This function reads the alternate zero (Single Axis) reference value.

Syntax: `double Single_Alt_Zero_Value(int sensorNumber)`

Arguments: Name Type Description

```

sensorNumber    int    The target sensor module number
                    (1-4).
Return Value:    Alternate Zero (Single Axis) reference value.
Remarks:        • This function stores the current single-axis reading
                    as a reference inside the DLL.
                    • The alternate zero reference remains active until Sin-
                    gle_Alt_Zero_Clear() is called.
Code Example:    double value = DWL500XYLibrary.SerialComm.Single_Alt_
                    Zero_Value(1);
    
```

5.3.2. Using the DWL5500XY Dynamic Link Library

This function is only for use DWL-5500XY Sensor Module Through Digi-Pas Control Box.

5.3.2.1. DWL5500XYLibrary.SerialComm.Serial_Initialization

Description: Initializes and configures the serial communication inter-
face for connecting to the device.

```

public static bool Serial_Initialization(string PortName);
Syntax:    bool Serial_Initialization(string portName)
    
```

Arguments:

Name	Type	Description
portName	string	Name of the COM port to connect to (for example, "COM15").

Return Value: True - Serial initialization successfully
False - Fault occurred during serial initialization

Remarks: The serial communication interface is initialized with the following settings:

- BaudRate : 115200
- Parity : None
- DataBits : 8
- StopBits: One
- FlowControl: None

Code Example: `bool result = DWL5500XYLibrary.SerialComm.Serial_Initialization("COM15");`

5.3.2.2. DWL5500XYLibrary.SerialComm.Mode

Description: Sends a direct mode command to a specific sensor module with raw parameter bytes.

Syntax: `void Mode(int sensor,int mode,int data2,int data3, int data4, int data5, int data6)`

Arguments: Mode The mode selection.
data1~data5 Parameters to pass to the selected mode.

Return Value: None

Remarks:	Name	Type	Description
	Sensor mode	Int	Target sensor module index (1-4).
	data2	int	Mode command identifier.
	data3	int	Mode-specific parameter byte 1.
	data4	int	Mode-specific parameter byte 2.
	data5	int	Mode-specific parameter byte 3.
	data6	int	Mode-specific parameter byte 4.
		int	Mode-specific parameter byte 5.

Code Example:

```
Sensor Connection Status : DWL5500XYLibrary.SerialComm.Mode(0x01, 0x55, 0, 0, 0, 0, 0);
Single Axis Mode : DWL5500XYLibrary.SerialComm.Mode(0x01, 0x01, 0, 0, 0, 0, 0);
Dual Axis Mode : DWL5500XYLibrary.SerialComm.Mode(0x01, 0x02, 0, 0, 0, 0, 0);
Vibro Mode : DWL5500XYLibrary.SerialComm.Mode(0x01, 0x03, 0, 0, 0, 0, 0);
```

5.3.2.3.DWL5500XYLibrary.SerialComm.set_location

Description: This function configures the sensor location. User can refer to APPENDIX 2: Country and City Index for the list.

Syntax public static void set_location (int country_index, int city country_index)

Arguments: country index & city index number.

Return Value: None

Code Example: DWL5500XYLibrary.SerialComm.set_location(0x05, 0x01);

5.3.2.4.DWL5500XYLibrary.SerialComm.Stand

Description: This function reads the device position is in Single Axis mode or Dual Axis mode.

Prototype: int Stand(int sensor_number)

Arguments:	Name	Type	Description
	sensor_number	int	Sensor Module index (1-4)

Return Value: 1 - Device is in Single Axis Mode
2 - Device is in Dual Axis Mode

Code Example: int position = DWL5500XYLibrary.SerialComm.Stand(1);

5.3.2.5.DWL5500XYLibrary.SerialComm.Sensor_Connection_Status

Description: Checks whether the specified sensor module is currently connected.

Syntax: int Sensor_Connection_Status(int sensor_number)

Arguments:

Name	Type	Description
sensor_number	int	The target sensor module number (1-4).

Return Value:

0 - Sensor module is not connected
 1 - Sensor module is connected

Remarks:

- This function returns the connection status of the specified sensor module.
- It is applicable when using a Control Box configuration that supports multiple sensor modules.
- Use Mode(0x55, 0, 0, 0, 0, 0) to enable sensor status mode.

Code Example:

```
// request sensor status
DWL5500XYLibrary.SerialComm.Mode(0x55, 0, 0, 0, 0, 0);
// Read sensor status
int isConnected = DWL5500XYLibrary.SerialComm.Sensor_Connection_Status(1);
```

5.3.2.6.DWL5500XYLibrary.SerialComm.Dual_X_Value

Description:

Reads the X-axis measurement value.

Syntax:

double Dual_X_Value (int sensor_number)

Arguments:

Name	Type	Description
sensor_number	int	The target sensor module number (1-4).

Return Value:

Returns the current X-axis measurement value reported by the sensor.

Remarks:

- Before calling this function, the device must be configured for Dual Axis Measurement mode.
- Use Mode(0x02, 0, 0, 0, 0, 0) to enable dual axis measurement mode.

Code Example:

```
// Enable Dual Axis measurement mode
DWL5500XYLibrary.SerialComm.Mode(0x02, 0, 0, 0, 0, 0);
// Read X axis value
double x = DWL5500XYLibrary.SerialComm.Dual_X_Value(1);
```

5.3.2.7.DWL5500XYLibrary.SerialComm.Dual_Y_Value

Description:

Reads the Y-axis measurement value.

Syntax:

double Dual_Y_Value(int sensor_number)

Arguments:

Name	Type	Description
sensor_number	int	Sensor Module index (1-4)

Return Value: Returns the current Y-axis measurement value reported by the sensor.

Remarks:

- Before calling this function, the device must be configured for Dual Axis Measurement mode.
- Use Mode(0x02, 0, 0, 0, 0, 0) to enable dual axis measurement mode.

Code Example:

```
// Enable Dual Axis measurement mode
DWL5500XYLibrary.SerialComm.Mode(0x02, 0, 0, 0, 0, 0);
// Read Y axis value
double y = DWL5500XYLibrary.SerialComm.Dual_Y_Value(1);
```

5.3.2.8.DWL5500XYLibrary.SerialComm.Single_Value

Description: Reads the Single axis measurement value.

Syntax: double Single_Value(int sensor_number)

Arguments:

Name	Type	Description
sensor_number	int	Sensor Module index (1-4)

Return Value: Returns the current X-Axis measurement value reported by the sensor.

Remarks:

- Before calling this function, the device must be configured for Single Axis Measurement mode.
- Use Mode(0x01 0, 0, 0, 0, 0) to enable single axis measurement mode.

Code Example:

```
// Enable single Axis measurement mode
DWL5500XYLibrary.SerialComm.Mode(0x01, 0, 0, 0, 0, 0);
// Read x axis value
double single_value = DWL5500XYLibrary.SerialComm.single_value(1);
```

5.3.2.9.DWL5500XYLibrary.SerialComm.Vibro_Value

Description: This function reads the vibro value.

Syntax: double Vibro_Value(int sensor_number)

Arguments:

Name	Type	Description
sensor_number	int	Sensor module index (1-4)

Return Value: Returns the current vibration measurement value reported by the sensor.

Remarks:

- Before calling this function, the device must be configured for vibration measurement mode.
- Use Mode(0x03, 0, 0, 0, 0, 0) to enable vibro measurement mode.

```
Code Example: // Enable vibration measurement mode
              DWL5500XYLibrary.SerialComm.Mode(0x03, 0, 0, 0, 0, 0);
              // Read vibration value
              double vibro = DWL5500XYLibrary.SerialComm.Vibro_Value(1);
```

5.3.2.10. DWL5500XYLibrary.SerialComm.Single_Alt_Zero_Set

Description: Defines the current single-axis measurement as the alternate zero reference for a specified sensor.

Syntax: void Single_Alt_Zero_Set(int sensor_number)

Arguments:

Name	Type	Description
sensorNumber	Int	The target sensor module number (1-4).

Return Value: None

Remarks:

- This function stores the current single-axis reading as a reference inside the DLL.
- The alternate zero reference remains active until Single_Alt_Zero_Clear() is called.

```
Code Example: double value = DWL5500XYLibrary.SerialComm.Single_Alt_Zero_Set(1);
```

5.3.2.11. DWL5500XYLibrary.SerialComm.Single_Alt_Zero_clear

Description: Disables alternate zero and clears the stored reference value.

Syntax: void Single_Alt_Zero_Clear(int sensorNumber)

Arguments:

Name	Type	Description
sensorNumber	int	The target sensor module number (1-4).

Return Value: None.

Remarks:

- Clears the alternate zero reference and restores normal absolute single-axis measurement output.

```
Code Example: DWL5500XYLibrary.SerialComm.Single_Alt_Zero_clear(1);
```

5.3.2.12. DWL5500XYLibrary.SerialComm.Single_Alt_Zero_Value

Description: This function reads the alternate zero (Single Axis) reference value.

Syntax: public static double Single_Alt_Zero_Value(int sensor_number)

Arguments:

Name	Type	Description
------	------	-------------

sensorNumber int The target sensor module number (1-4).

Return Value: Alternate Zero (Single Axis) reference value.

- Remarks:**
- This function stores the current single-axis reading as a reference inside the DLL.
 - The alternate zero reference remains active until Single_Alt_Zero_Clear() is called.

Code Example: double value = DWL5500XYLibrary.SerialComm.Single_Alt_Zero_Value(1);

5.3.2.13. DWL5500XYLibrary.SerialComm.Dual_Alt_Zero_Set

Description: Defines the current dual-axis (X and Y) measurements as the alternate zero reference for a specified sensor.

Syntax: void Dual_Alt_Zero_Set(int sensorNumber)

Arguments:

Name	Type	Description
sensorNumber	int	The target sensor module number (1-4).

Return Value: None

- Remarks:**
- This function captures the current X-axis and Y-axis measurements and stores them internally as the alternate zero reference.
 - When alternate zero is enabled, subsequent dual-axis readings are reported as relative values (delta) from this reference.

Code Example: DWL5500XYLibrary.SerialComm.Dual_Alt_Zero_Set(1);

5.3.2.14. DWL5500XYLibrary.SerialComm.Dual_Alt_Zero_Clear

Description: Clears the stored X and Y alternate zero references and restores normal absolute dual-axis measurement output.

Syntax: void Dual_Alt_Zero_Clear(int sensorNumber)

Arguments:

Name	Type	Description
sensorNumber	int	The target sensor module number (1-4).

Return Value: None

- Remarks:**
- Clears the alternate zero reference and restores normal absolute single-axis measurement output.

Code Example: DWL5500XYLibrary.SerialComm.Dual_Alt_Zero_Clear(1);

5.3.2.15. DWL5500XYLibrary.SerialComm.Dual_x_Alt_Zero_Value

Description: Reads the X-axis measurement relative to the alternate zero reference.

Syntax: double Dual_x_Alt_Zero_Value(int sensorNumber)

Arguments:

Name	Type	Description
sensorNumber	int	The target sensor module number (1-4).

Return Value:

Returns the relative X-axis measurement (current X minus alternate zero reference).

Remarks:

- If alternate zero is enabled, this function returns the delta between the live X-axis measurement and the stored reference value.
- If alternate zero is disabled, the absolute X-axis measurement is returned.

Code Example:

```
double x = DWL5500XYLibrary.SerialComm.Dual_x_Alt_Zero_Value(1);
```

6. DWL5500XYLibrary.SerialComm.Dual_y_Alt_Zero_Value

Description:

Reads the Y-axis measurement relative to the alternate zero reference.

Syntax:

```
double Dual_y_Alt_Zero_Value(int sensorNumber)
```

Arguments:

Name	Type	Description
sensorNumber	int	The target sensor module number (1-4).

Return Value:

Returns the relative Y-axis measurement (current Y minus alternate zero reference).

Remarks:

- If alternate zero is enabled, this function returns the delta between the live Y-axis measurement and the stored reference value.
- If alternate zero is disabled, the absolute Y-axis measurement is returned.

Code Example:

```
double y = SerialComm.Dual_y_Alt_Zero_Value(1);
```

7. RS485/RS232 Serial Communication Protocol for Single DWL5x00XY Tilt Sensor

7.1. Serial Port Settings

Following are the serial port settings to enable the serial communication:

Baud Rate	115200
Parity	None
Data Bits	8
Stop Bits	1 Stop Bit
Handshake	None

7.2. Buffer Frame Format

Buffer Format : Hexadecimal
 Buffer Length : 12 bytes

The data to be transmitted out to tilt sensor module is as follow:

Source	Destination	Mode	Data
1 Byte	1 Byte	1 Byte	1 Byte

Source (1 byte) : Sender command
 Destination (1 byte) : Receiver command
 Mode (1 byte) : Mode Selection command
 Data (9 bytes) : Data to be sent out

The data to be received from the tilt sensor module is as follow:

Source/Destination	Stand/Mode	Data	CRC16
1 Byte	1 Byte	8 Bytes	2 Bytes

Source (4 bits) : Sender command
 Destination (4 bits) : Receiver command
 Stand (4 bits) : Position in either Single or Dual Axis
 Mode (4 bits) : Mode Selection command
 Data (8 bytes) : Received data

7.3. Initialization Command

Please send the following buffer to initialize the sensor through serial converter:
 << (To sensor): 0x06, 0x24, 0x00, 0x00, 0x00, 0x00, 0x00, 0x00, 0x00, 0x00, 0x00, 0x00

7.4. Commands for Source and Destination

Both the source and destination have the same command as listed below:

Command	Descriptions
0x01	Sensor
0x06	Computer
0x07	Control Box

i.e. Command for selection of Single Axis Mode from Computer to Sensor 1:

Byte[0]	Byte[1]	Byte[2]	Byte[3]	Byte[4]	Byte[5]	Byte[6]	Byte[7]	Byte[8]	Byte[9]	Byte[10]	Byte[11]
0x06	0x01	0x01	0xAA	0x00	0x00	0x00	0x00	0x00	0x00	0x00	0x00

Byte[n]	Byte[0]	Byte[1]	Byte[2]	Byte[3]	Byte[4]..[11]
Byte description	Source	Destination	Mode	Data	Data
Command	0x06	0x01	0x01	0xAA	0x00
Command description	Computer	Sensor	Single Axis Mode	Dummy	Dummy

7.5. Commands for Mode Selection

Following shows the command of mode selection:

Command	Descriptions
0x01	Single Axis Mode
0x02	Dual Axis Mode
0x03	Vibro Mode
0x0B	Calibration Mode
0x07	Alternate Zero in Single Axis Mode
0x0A	Alternate Zero in Dual Axis Mode
0x08	Location Mode

The detailed information of each command is explained in Section 6.5.1 to 6.5.7. Please note that all the angle values and CRC16 values are for illustration purposes only.

7.5.1. Single Axis Mode

To set the tilt sensor module into Single Axis Mode:

<< (To sensor) : 0x06, 0x01, 0x01, 0xAA, 0x00, 0x00, 0x00, 0x00, 0x00, 0x00, 0x00, 0x00

Byte [n]	Command	Descriptions
Byte [0]	0x06	From Computer
Byte [1]	0x01	To Sensor
Byte [2]	0x01	Single Axis Mode
Byte [3]	0xAA	Dummy
Byte [4]~ [11]	0x00	Not Applicable

Data received from tilt sensor module:

>> (From sensor) : 0x61, 0x11, 0x01, 0x12, 0xA8, 0x80, 0x01, 0x13, 0x88, 0xAA, 0x16, 0x46

Byte [n]	Command	Descriptions
Byte [0]	0x61	To Computer / From Sensor
Byte [1]	0x11	Single Axis Position / Single Axis Mode
Byte [2]	0x01	Angle Value
Byte [3]	0x12	
Byte [4]	0xA8	
Byte [5]	0x80	
Byte [6]	0x01	Single Axis Position
Byte [7]	0x13	Not Applicable
Byte [8]	0x88	Not Applicable
Byte [9]	0xAA	Dummy
Byte [10]	0x16	CRC16 High
Byte [11]	0x46	CRC16 Low

Following equation shows the conversion of angle from the received data:

For DWL5800XY

$$\text{Decimal Degree} = (((\text{Byte [5]} \ll 24) + (\text{Byte [4]} \ll 16) + (\text{Byte [3]} \ll 8) + \text{Byte [2]}) - 18000000) / 100000) * 3600$$

For DWL5500XY

$$\text{Decimal Degree} = (((\text{Byte [5]} \ll 24) + (\text{Byte [4]} \ll 16) + (\text{Byte [3]} \ll 8) + \text{Byte [2]}) - 18000000) / 100000$$

For DWL5000XY

$$\text{Decimal Degree} = (((\text{Byte [5]} \ll 24) + (\text{Byte [4]} \ll 16) + (\text{Byte [3]} \ll 8) + \text{Byte [2]}) - 1800000) / 10000$$

* Please ensure that Byte 2 returns 0x11 when using Single Axis Mode

7.5.2. Dual Axis Mode

To set the tilt sensor module into Dual Axis Mode:

<< (To sensor) : 0x06, 0x01, 0x02, 0xAA, 0x00, 0x00, 0x00, 0x00, 0x00, 0x00, 0x00, 0x00

Byte [n]	Command	Descriptions
Byte [0]	0x06	From Computer
Byte [1]	0x01	To Sensor
Byte [2]	0x02	Dual Axis Mode
Byte [3]	0xAA	Dummy
Byte [4]~[11]	0x00	Not Applicable

Data received from tilt sensor module:

>> (From sensor) : 0x61, 0x22, 0x2D, 0xC6, 0xC0, 0x2D, 0xC6, 0xC0, 0x13, 0x88, 0x31, 0xE2

Byte [n]	Command	Descriptions
Byte [0]	0x61	To Computer / From Sensor
Byte [1]	0x22	Dual Axis Position / Dual Axis Mode
Byte [2]	0x2D	Angle Y Value
Byte [3]	0xC6	
Byte [4]	0xC0	
Byte [5]	0x2D	Angle X Value
Byte [6]	0xC6	
Byte [7]	0xC0	
Byte [8]	0x13	Not Applicable
Byte [9]	0x88	Not Applicable
Byte [10]	0x31	CRC16 High
Byte [11]	0xE2	CRC16 Low

Following equation shows the conversion of angle from the received data:

For DWL5800XY

$$\text{Decimal Degree Y} = (((\text{Byte [4]} \ll 16) + (\text{Byte [3]} \ll 8) + \text{Byte [2]}) - 3000000) / 100000) * 3600$$

$$\text{Decimal Degree X} = (((\text{Byte [7]} \ll 16) + (\text{Byte [6]} \ll 8) + \text{Byte [5]}) - 3000000) / 100000) * 3600$$

For DWL5500XY

$$\text{Decimal Degree Y} = (((\text{Byte [4]} \ll 16) + (\text{Byte [3]} \ll 8) + \text{Byte [2]}) - 3000000) / 100000$$

$$\text{Decimal Degree X} = (((\text{Byte [7]} \ll 16) + (\text{Byte [6]} \ll 8) + \text{Byte [5]}) - 3000000) / 100000$$

For DWL5000XY

$$\text{Decimal Degree Y} = (((\text{Byte [4]} \ll 16) + (\text{Byte [3]} \ll 8) + \text{Byte [2]}) - 300000) / 10000$$

$$\text{Decimal Degree X} = (((\text{Byte [7]} \ll 16) + (\text{Byte [6]} \ll 8) + \text{Byte [5]}) - 300000) / 10000$$

* Please ensure that Byte 2 returns 0x22 when using Dual Axis Mode

7.5.3. Vibro Mode

To set the tilt sensor module into Vibro Mode:

<< (To sensor) : 0x06, 0x01, 0x03, 0xAA, 0x00, 0x00, 0x00, 0x00, 0x00, 0x00, 0x00, 0x00

Byte [n]	Command	Descriptions
Byte [0]	0x06	From Computer
Byte [1]	0x01	To Sensor
Byte [2]	0x03	Vibro Mode
Byte [3]	0xAA	Dummy
Byte [4]~[11]	0x00	Not Applicable

Data received from tilt sensor module:

>> (From sensor) : 0x61, 0x13, 0x00, 0x03, 0xD0, 0x90, 0xCC, 0xCC, 0xCC, 0xCC, 0xAA, 0x3A

Byte [n]	Command	Descriptions
Byte [0]	0x61	To Computer / From Sensor
Byte [1]	0x13	Single Axis Position / Vibro Mode
Byte [2]	0x00	Vibro Value
Byte [3]	0x03	
Byte [4]	0xD0	
Byte [5]	0x90	
Byte [6]	0xCC	Fixed Dummy
Byte [7]	0xCC	
Byte [8]	0xCC	
Byte [9]	0xCC	
Byte [10]	0xAA	CRC16 High
Byte [11]	0x3A	CRC16 Low

Following equation shows the conversion of angle from the received data:

For DWL5800XY

$$\text{Vibrometer g} = \frac{(((\text{Byte [5]} \ll 24) + (\text{Byte [4]} \ll 16) + (\text{Byte [3]} \ll 8) + \text{Byte [2]}) - 250000)}{100000}$$

For DWL5500XY

$$\text{Vibrometer g} = \frac{(((\text{Byte [5]} \ll 24) + (\text{Byte [4]} \ll 16) + (\text{Byte [3]} \ll 8) + \text{Byte [2]}) - 250000)}{100000}$$

For DWL5000XY

$$\text{Vibrometer g} = \frac{(((\text{Byte [5]} \ll 24) + (\text{Byte [4]} \ll 16) + (\text{Byte [3]} \ll 8) + \text{Byte [2]}) - 25000)}{10000}$$

7.5.4. Calibration Mode

To set the tilt sensor module into Calibration Mode:

<< (To sensor) : 0x06, 0x01, 0x0B, 0xA0, 0x00, 0x00, 0x00, 0x00, 0x00, 0x00, 0x00, 0x00

<< (To sensor) : 0x06, 0x01, 0x0B, 0xB0, 0x00, 0x00, 0x00, 0x00, 0x00, 0x00, 0x00, 0x00

Byte [n]	Command	Descriptions
Byte [0]	0x06	From Computer
Byte [1]	0x01	To Sensor
Byte [2]	0x0B	Calibration Mode
Byte [3]	0xA0	0xA0 : Acknowledgement 0xB0 : Start current calibration step
Byte [4]~[11]	0x00	Not Applicable

Data received from tilt sensor module:

>> (From sensor) : 0x61, 0x1B, 0x00, 0x00, 0x13, 0x01, 0x88, 0xDD, 0xDD, 0xDD, 0xAA, 0x3A

Byte [n]	Command	Descriptions
Byte [0]	0x61	To Computer / From Sensor
Byte [1]	0x1B	Single Axis Position / Calibration Mode
Byte [2]	0x00	Calibration Feedback 0x17 : Idle /Current calibration step finished 0x0A : Counting
Byte [3]	0x00	Calibration Count 0x01 - 0x1E : Counting Up
Byte [4]	0x13	Not Applicable
Byte [5]	0x01	Calibration Step 0x01: Calibration Step 1 ready 0x02: Calibration Step 2 ready 0x03: Calibration Step 3 ready 0x04: Calibration Step 4 ready 0x05: Calibration Step 5 ready 0x06: Calibration Step 6 ready 0x07: Calibration Step 7 ready 0x08: Calibration Step 8 ready
Byte [6]	0x88	Not Applicable
Byte [7]~[9]	0xDD	Fixed Dummy
Byte [10]	0xAA	CRC16 High
Byte [11]	0x3A	CRC16 Low

It is advised to perform calibration of the tilt sensor module in a controlled temperature setting.

* Please refer to 6.5.4.1 for detailed calibration steps

7.5.4.1. Detailed Calibration Steps :

1. Please refer to Appendix 1 for proper instrument setup for calibration. Send the following command from computer to respective sensor to make sure the sensor is ready for calibration mode:

<< (To sensor): 0x06, 0x01, 0x0B, 0xA0, 0x00, 0x00, 0x00, 0x00, 0x00, 0x00, 0x00, 0x00

Byte [n]	Command	Descriptions
Byte [0]	0x06	From Computer
Byte [1]	0x01	To Sensor
Byte [2]	0x0B	Calibration Mode
Byte [3]	0xA0	Acknowledgement to sensor module
Byte [4]~[11]	0x00	Not Applicable

- Wait for response from the sensor. Once the calibration mode is activated, last 4 bits of Byte 2 will show 0xB and Byte 6 will show 0x01.

>> (From sensor) : 0x61, 0x1B, 0x00, 0x00, 0x13, 0x01, 0x88, 0xDD, 0xDD, 0xDD, 0x22, 0x93

Byte [n]	Command	Descriptions
Byte [0]	0x61	To Computer / From Sensor
Byte [1]	0x1B	Single Axis Position / Calibration Mode
Byte [2]	0x00	Calibration Feedback
Byte [3]	0x00	Calibration Count
Byte [4]	0x13	Not Applicable
Byte [5]	0x01	0x01: Calibration Step 1 ready
Byte [6]	0x88	Not Applicable
Byte [7]~[9]	0xDD	Fixed Dummy
Byte [10]	0xAA	CRC16 High
Byte [11]	0x93	CRC16 Low

- Locate the sensor module as following Figure 35. The sensor is ready for user to perform calibration step 1.

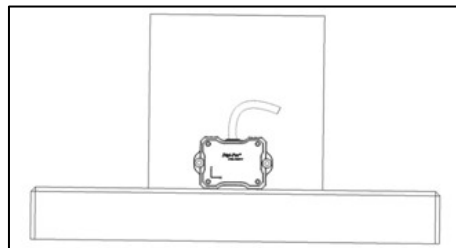

Figure 35. Tilt Sensor Module Position of Calibration Step 1

- Send the following command from computer to respective sensor to trigger on the calibration step 1:

<< (To sensor): 0x06, 0x01, 0x0B, 0xB0, 0x00, 0x00, 0x00, 0x00, 0x00, 0x00, 0x00, 0x00

Byte [n]	Command	Descriptions
Byte [0]	0x06	From Computer
Byte [1]	0x01	To Sensor
Byte [2]	0x0B	Calibration Mode
Byte [3]	0xB0	Start Application
Byte [4]~[11]	0x00	Not Applicable

- Wait for response from the sensor. The sensor will broadcast the following response with Byte 4 counting from 0x00 to 0x1E. Once Byte 4 counts to 0x1E, Byte 3 shows 0x17 from 0x0A and Byte 6 shows 0x02, calibration step 1 is completed. If Byte 3 from sensor response **is not equal** to 0x17 and Byte 6 response **is not equal** to 0x02 after Byte 4 is counted to 0x1E, restart (power off and power on again) the sensor module and redo the calibration

process from the beginning (Step 1).

>> (From sensor): 0x61, 0x1B, 0x17, 0x1E, 0x13, 0x02, 0x88, 0xDD, 0xDD, 0xDD, 0x22, 0x93

Byte [n]	Command	Descriptions
Byte [0]	0x61	To Computer / From Sensor
Byte [1]	0x1B	Single Axis Position / Calibration Mode
Byte [2]	0x17	Calibration Feedback : Idle
Byte [3]	0x1E	Calibration Count : 30
Byte [4]	0x13	Not Applicable
Byte [5]	0x02	Calibration Step 2 Ready
Byte [6]	0x88	Not Applicable
Byte [7]~[9]	0xDD	Fixed Dummy
Byte [10]	0x22	CRC16 High
Byte [11]	0x93	CRC16 Low

6. Locate the sensor module as following Figure 36. The sensor is ready for user to perform calibration step 2.

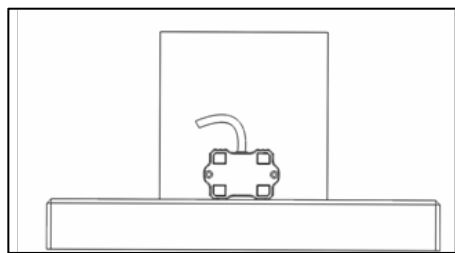

Figure 36. Tilt Sensor Module Position of Calibration Step 2

7. Repeat Step 4 to trigger the calibration step 2:

<< (To sensor): 0x06, 0x01, 0x0B, 0xB0, 0x00, 0x00, 0x00, 0x00, 0x00, 0x00, 0x00, 0x00

8. Wait for response from the sensor. The sensor will broadcast the following response with Byte 4 counting from 0x00 to 0x1E. Once Byte 4 counts to 0x1E, Byte 3 shows 0x17 from 0x0A and Byte 6 shows 0x03, calibration step 2 is completed. If Byte 3 from sensor response **is not equal** to 0x17 and Byte 6 response **is not equal** to 0x03 after Byte 4 is counted to 0x1E, restart (power off and power on again) the sensor module and redo the calibration process from the beginning (Step 1).

>> (From sensor): 0x61, 0x1B, 0x17, 0x1E, 0x13, 0x03, 0x88, 0xDD, 0xDD, 0xDD, 0x22, 0x93

Byte [n]	Command	Descriptions
Byte [0]	0x61	To Computer / From Sensor
Byte [1]	0x1B	Single Axis Position / Calibration Mode
Byte [2]	0x17	Calibration Feedback : Idle
Byte [3]	0x1E	Calibration Count : 30
Byte [4]	0x13	Not Applicable
Byte [5]	0x03	Calibration Step 3 Ready
Byte [6]	0x88	Not Applicable
Byte [7]~[9]	0xDD	Fixed Dummy
Byte [10]	0x22	CRC16 High
Byte [11]	0x93	CRC16 Low

9. For **DWL5000XY** model, repeat step 3 to step 8. Please locate the sensor module in following positions (refer to Figure 37 to Figure 42) respectively.
10. For **DWL5000XY & DWL5800XY** model, please perform only 4 steps calibration as shown in Figure 35, 36, 41, and 42.
11. Once the following response is received, the calibration process is completed.

>> (From sensor): 0x61, 0x2B, 0x17, 0x1E, 0x13, 0x08, 0x88, 0xDD, 0xDD, 0xDD, 0x22, 0x93

The sensor module will automatically change to dual axis mode and broadcast dual axis angle measurement (Please refer to 6.5.2 Dual Axis Mode) after the calibration process is completed.

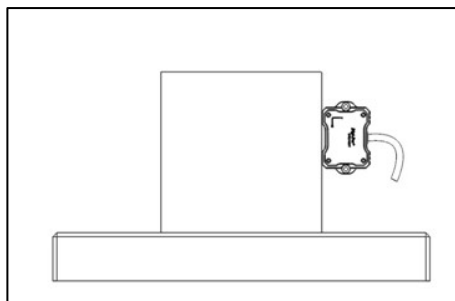

Figure 37. Tilt Sensor Module Position of Calibration Step 3

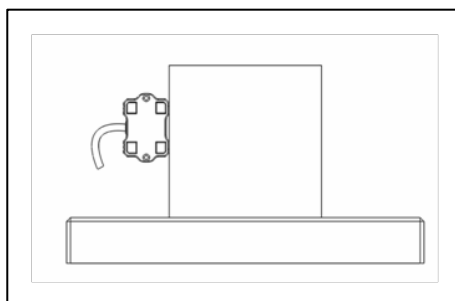

Figure 38. Tilt Sensor Module Position of Calibration Step 4

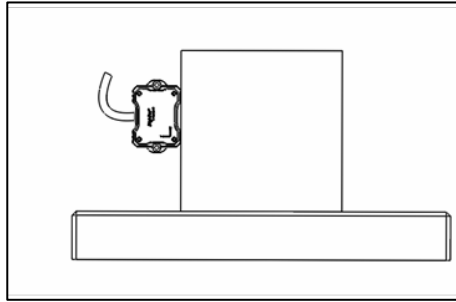

Figure 39. Tilt Sensor Module Position of Calibration Step 5

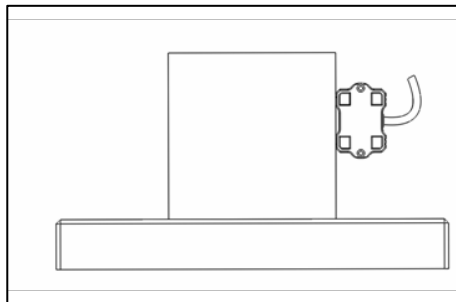

Figure 40. Tilt Sensor Module Position of Calibration Step 6

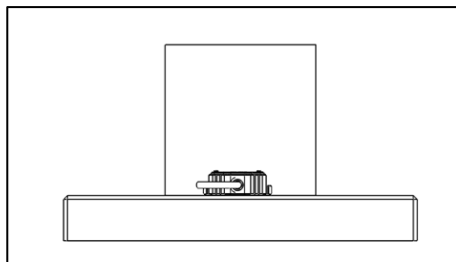

Figure 41. Tilt Sensor Module Position of Calibration Step 7

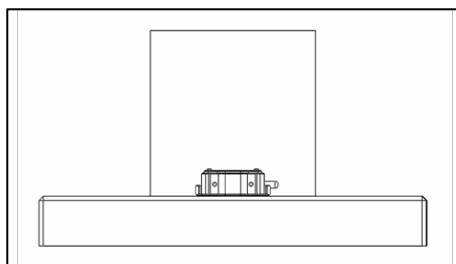

Figure 42. Tilt Sensor Module Position of Calibration Step 8

7.5.5. Absolute Level in Single & Dual Axis Mode Calculation

To set the device in absolute level measurement, please follow the following calculation formula:

$$\text{Absolute offset data} = (\text{Front Measurement Position Value} + \text{Back Measurement Position Value}) / 2$$

$$\text{Absolute Level mode measurement} = \text{Measurement data} - \text{absolute offset data}$$

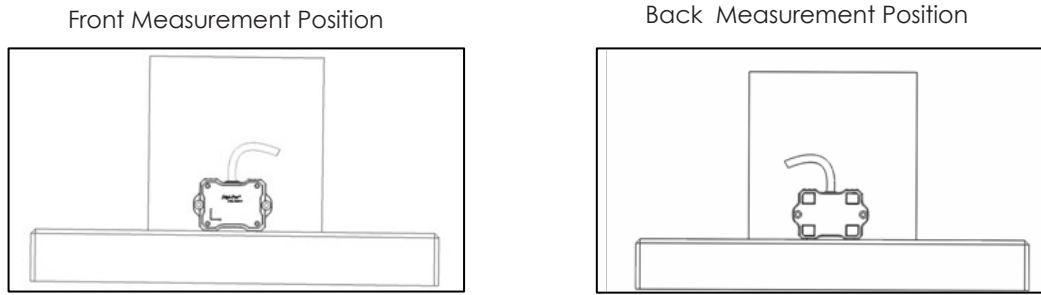

Example sensor position illustration in absolute offset setup for single-axis mode

Example:

Front Measurement Position Value = 1.5 °

Back Measurement Position Value = - 2.3 °

Absolute offset data = (Front Measurement Position Value + Back Measurement Position Value) / 2

Absolute offset data = (1.5 ° + (- 2.3°)) / 2

Absolute offset data = **- 0.4 °**

Absolute Level mode measurement = Measurement data - Absolute offset data

Absolute Level mode measurement = 1.5 ° - (-0.4 °)

Absolute Level mode measurement = **1.9°**

Note:

- Absolute offset data required to perform on predetermined measurement surfaces.
- Ensure the device front position measurement & back position measurement are align in the same position with perfect 180° rotation.
- For Dual Axis absolute level offset calculations, the X & Y-Axis require to calculate separately as the offset value for both axis could be different.

7.5.6. Location Setting*

To set location :

<< (To sensor) : 0x06, 0x01, 0x08, 0x00, 0x00, 0x00, 0x00, 0x5A, 0x00, 0x00, 0x00, 0x00

Byte [n]	Command	Descriptions
Byte [0]	0x06	From Computer
Byte [1]	0x01	To Sensor
Byte [2]	0x08	Location Mode
Byte [3]	0x00	Country Index** (Please refer to Appendix 2 Country and City index)
Byte [4]	0x00	City Index** (Please refer to Appendix 2 Country and City index)
Byte [5]~[6]	0x00	Not Applicable
Byte [7]	0x5A	Location Write Command
Byte [8]~[11]	0x00	Not Applicable

*Only require for for sensor module model DWL-5500XY & DWL-5800XY

**User is required to select the country and city (or its nearest city/location) where device is operating

***User can refer to APPENDIX 2: Country and City Index for the list of the

Data received from tilt sensor module:

>> (From sensor) : 0x61 0x18, 0x00, 0x00, 0x00, 0x00, 0x00, 0x00, 0x00, 0x00, 0x00, 0x00

8. Serial Communication Protocol for Control Box

8.1. Serial Port Settings

Following are the serial port settings to enable the serial communication:

Baud Rate	115200
Parity	None
Data Bits	8
Stop Bits	1 Stop Bit
Handshake	None

8.2. Buffer Frame Format

Buffer Format : Hexadecimal

Buffer Length : 12 bytes

The data to be transmitted out to tilt sensor module is as follow:

Source	Destination	Data
1 Byte	1 Byte	10 Byte

Source (1 byte) : Sender command

Destination (1 byte) : Receiver command
 Mode (1 byte) : Mode Selection command

The data to be received from the tilt sensor module is as follow:

Source/Destination	Stand/Mode	Data	CRC16
1 Byte	1 Byte	8 Bytes	2 Bytes

Source (4 bits) : Sender command
 Destination (4 bits) : Receiver command
 Stand (4 bits) : Position in either Single or Dual Axis
 Mode (4 bits) : Mode Selection command
 Data (8 bytes) : Received data

8.3. Commands for Source and Destination

Both the source and destination have the same command as listed below:

Command	Descriptions
0x01	Sensor 1
0x02	Sensor 2
0x03	Sensor 3
0x04	Sensor 4
0x05	All sensor
0x06	Computer
0x07	Control Box

i.e. Command for selection of Single Axis Mode from Computer to Control Box:

Byte[0]	Byte[1]	Byte[2]	Byte[3]	Byte[4]	Byte[5]	Byte[6]	Byte[7]	Byte[8]	Byte[9]	Byte[10]	Byte[11]
0x06	0x01	0x00	0x00	0x00	0x00	0x00	0x00	0x00	0x00	0x00	0x00

Byte[n]	Byte[0]	Byte[1]	Byte[2]..[11]
Byte description	Source	Mode	Data
Command	0x06	0x01	0x00
Command description	Computer	Single Axis Mode	Dummy

8.4. Commands for Mode Selection

Following shows the command of mode selection:

Command	Descriptions
0x01	Single Axis Mode
0x02	Dual Axis Mode
0x03	Vibro Mode
0x0B	Calibration Mode
0x07	Alternate Zero in Single Axis Mode
0x0A	Alternate Zero in Dual Axis Mode
0x20	Relay Mode
0x55	Connection Status Mode

The detailed information of each command is explained in Section 7.4.1 to 7.4.7 Please note that all the angle values and CRC16 values are for illustration purposes only.

8.4.1. Single Axis Mode

To set the tilt sensor module into Single Axis Mode:

<< (To control box) : 0x06, 0x01, 0x00, 0x00, 0x00, 0x00, 0x00, 0x00, 0x00, 0x00, 0x00, 0x00

Byte [n]	Command	Descriptions
Byte [0]	0x06	From Computer
Byte [1]	0x01	Single Axis Mode
Byte [2]	0x01	Not Applicable
Byte [3]~[11]	0x00	

Data received from control box:

>> (From control box) : 0x71, 0x11, 0x01, 0x12, 0xA8, 0x80, 0x01, 0x13, 0x88, 0xAA, 0x16, 0x46

Byte [n]	Command	Descriptions
Byte [0]	0x71	0x71: To Control Box / From Sensor 1 0x72: To Control Box / From Sensor 2 0x73: To Control Box / From Sensor 3 0x74: To Control Box / From Sensor 4
Byte [1]	0x11	Single Axis Position / Single Axis Mode
Byte [2]	0x01	Angle Value
Byte [3]	0x12	
Byte [4]	0xA8	
Byte [5]	0x80	
Byte [6]	0x01	Single Axis Position
Byte [7]	0x13	Not Applicable
Byte [8]	0x88	
Byte [9]	0xAA	Dummy
Byte [10]	0x16	CRC16 High
Byte [11]	0x46	CRC16 Low

Following equation shows the conversion of angle from the received data:

For DWL5800XY

$$\text{Decimal Degree} = (((\text{Byte [5]} \ll 24) + (\text{Byte [4]} \ll 16) + (\text{Byte [3]} \ll 8) + \text{Byte [2]}) - 18000000) / 100000) * 3600$$

For DWL5500XY

$$\text{Decimal Degree} = (((\text{Byte [5]} \ll 24) + (\text{Byte [4]} \ll 16) + (\text{Byte [3]} \ll 8) + \text{Byte [2]}) - 18000000) / 100000$$

For DWL5000XY

$$\text{Decimal Degree} = (((\text{Byte [5]} \ll 24) + (\text{Byte [4]} \ll 16) + (\text{Byte [3]} \ll 8) + \text{Byte [2]}) - 1800000) / 10000$$

* Please ensure that Byte 2 returns 0x11 when using Single Axis Mode

8.4.2. Dual Axis Mode

To set the tilt sensor module into Dual Axis Mode:

<< (To control box) : 0x06, 0x02, 0x00, 0x00, 0x00, 0x00, 0x00, 0x00, 0x00, 0x00, 0x00, 0x00, 0x00

Byte [n]	Command	Descriptions
Byte [0]	0x06	From Computer
Byte [1]	0x02	Dual Axis Mode
Byte [2]~[11]	0x00	Not Applicable

Data received from control box:

>> (From control box) : 0x71, 0x22, 0x2D, 0xC6, 0xC0, 0x2D, 0xC6, 0xC0, 0x13, 0x88, 0x31, 0xE2

Byte [n]	Command	Descriptions
Byte [0]	0x71	0x71: To Control Box / From Sensor 1 0x72: To Control Box / From Sensor 2 0x73: To Control Box / From Sensor 3 0x74: To Control Box / From Sensor 4
Byte [1]	0x22	Dual Axis Position / Dual Axis Mode
Byte [2]	0x2D	Angle Y Value
Byte [3]	0xC6	
Byte [4]	0xC0	
Byte [5]	0x2D	
Byte [6]	0xC6	Angle X Value
Byte [7]	0xC0	
Byte [8]	0x13	
Byte [9]	0x88	Not Applicable
Byte [10]	0x31	CRC16 High
Byte [11]	0xE2	CRC16 Low

Following equation shows the conversion of angle from the received data:

For DWL5800XY

Decimal Degree Y = (((Byte [4] << 16) + (Byte [3]<< 8) + Byte [2]) - 3000000) / 100000 * 3600
 Decimal Degree X = (((Byte [7] << 16) + (Byte [6] << 8) + Byte [5]) - 3000000) / 100000 * 3600

For DWL5500XY

Decimal Degree Y = (((Byte [4] << 16) + (Byte [3]<< 8) + Byte [2]) - 3000000) / 100000
 Decimal Degree X = (((Byte [7] << 16) + (Byte [6] << 8) + Byte [5]) - 3000000) / 100000

For DWL5000XY

Decimal Degree Y = (((Byte [4] << 16) + (Byte [3]<< 8) + Byte [2]) - 300000) / 10000
 Decimal Degree X = (((Byte [7] << 16) + (Byte [6] << 8) + Byte [5]) - 300000) / 10000

* Please ensure that Byte 2 returns 0x22 when using Dual Axis Mode

8.4.3. Vibro Mode

To set the tilt sensor module into Vibro Mode:

<< (To control box) : 0x06, 0x03, 0x00, 0x00, 0x00, 0x00, 0x00, 0x00, 0x00, 0x00, 0x00, 0x00

Byte [n]	Command	Descriptions
Byte [0]	0x06	From Computer
Byte [1]	0x03	Vibro Mode
Byte [2]~[11]	0x00	Not Applicable

Data received from control box:

>> (From control box) : 0x71, 0x13, 0x00, 0x03, 0xD0, 0x90, 0xCC, 0xCC, 0xCC, 0xCC, 0xAA, 0x3A

Byte [n]	Command	Descriptions
Byte [0]	0x71	0x71: To Control Box / From Sensor 1 0x72: To Control Box / From Sensor 2 0x73: To Control Box / From Sensor 3 0x74: To Control Box / From Sensor 4
Byte [1]	0x13	Single Axis Position / Vibro Mode
Byte [2]	0x00	Vibro Value
Byte [3]	0x03	
Byte [4]	0xD0	
Byte [5]	0x90	
Byte [6]	0xCC	Fixed Dummy
Byte [7]	0xCC	
Byte [8]	0xCC	
Byte [9]	0xCC	
Byte [10]	0xAA	CRC16 High
Byte [11]	0x3A	CRC16 Low

Following equation shows the conversion of angle from the received data:

For DWL5500XY & DWL5800XY

$$\text{Vibrometer } g = \frac{(((\text{Byte [5]} \ll 24) + (\text{Byte [4]} \ll 16) + (\text{Byte [3]} \ll 8) + \text{Byte [2]}) - 250000)}{100000}$$

For DWL5000XY

$$\text{Vibrometer } g = \frac{(((\text{Byte [5]} \ll 24) + (\text{Byte [4]} \ll 16) + (\text{Byte [3]} \ll 8) - 25000)}{10000}$$

8.4.4. Calibration Mode

To set the tilt sensor module into Calibration Mode:

<< (To control box) : 0x06, 0x0B, 0x05, 0xA0, 0x00, 0x00, 0x00, 0x00, 0x00, 0x00, 0x00, 0x00

<< (To control box) : 0x06, 0x0B, 0x05, 0xB0, 0x00, 0x00, 0x00, 0x00, 0x00, 0x00, 0x00, 0x00

Byte [n]	Command	Descriptions
Byte [0]	0x06	From Computer
Byte [1]	0x0B	Dual Axis Mode
Byte [2]	0x01	0x01: To Sensor 1 0x02: To Sensor 2 0x03: To Sensor 3 0x04: To Sensor 4 0x05: To all sensors
Byte [3]	0xA0	0xA0 :Acknowledgement 0xB0 :Start current calibration step
Byte [4]~[11]	0x00	Not Applicable

Data received from control box:

>> (From control box) : 0x71, 0x1B, 0x00, 0x00, 0x13, 0x01, 0x88, 0xDD, 0xDD, 0xDD, 0xAA, 0x3A

Byte [n]	Command	Descriptions
Byte [0]	0x71	0x71: To Control Box / From Sensor 1 0x72: To Control Box / From Sensor 2 0x73: To Control Box / From Sensor 3 0x74: To Control Box / From Sensor 4
Byte [1]	0x1B	Single Axis Position / Calibration Mode
Byte [2]	0x00	Calibration Feedback 0x17 : Idle / Current calibration step finished 0x0A : Counting
Byte [3]	0x00	Calibration Count 0x01 - 0x1E : Counting Up
Byte [4]	0x13	Not Applicable
Byte [5]	0x01	Calibration Step 0x01: Calibration Step 1 ready 0x02: Calibration Step 2 ready 0x03: Calibration Step 3 ready 0x04: Calibration Step 4 ready 0x05: Calibration Step 5 ready 0x06: Calibration Step 6 ready 0x07: Calibration Step 7 ready
Byte [6]	0x88	Not Applicable
Byte [7]~[9]	0xDD	Fixed Dummy
Byte [10]	0x13	CRC16 High
Byte [11]	0x01	CRC16 Low

It is advised to perform calibration of the tilt sensor module in a controlled temperature setting.

* Please refer to 7.4.4.1 for detailed calibration steps

8.4.4.1.Detailed Calibration Steps :

1. Please refer to Appendix 1 for proper instrument setup for calibration. Send the following command from computer to respective sensor to make sure the sensor is ready for calibration mode:

<< (To control box): 0x06, 0x0B, 0x05, 0xA0, 0x00, 0x00, 0x00, 0x00, 0x00, 0x00, 0x00

Byte [n]	Command	Descriptions
Byte [0]	0x06	From Computer
Byte [1]	0x0B	Calibration Mode
Byte [2]	0x05	To all sensors
Byte [3]	0xA0	Acknowledgement to sensor module
Byte [4]~[11]	0x00	Not Applicable

- Wait for response from the sensor. Once the calibration mode is activated, last 4 bits of Byte 2 will show 0xB and Byte 6 will show 0x01.

>> (From control box): 0x71, 0x1B, 0x00, 0x00, 0x13, 0x01, 0x88, 0xDD, 0xDD, 0xDD, 0x22, 0x93

Byte [n]	Command	Descriptions
Byte [0]	0x71	To Control Box / From Sensor 1
Byte [1]	0x1B	Single Axis Position / Calibration Mode
Byte [2]	0x00	Calibration Feedback
Byte [3]	0x00	Calibration Count
Byte [4]	0x13	Dummy
Byte [5]	0x01	Calibration Step 1 ready
Byte [6]	0x88	Dummy
Byte [7]~[9]	0xDD	Fixed Dummy
Byte [10]	0x22	CRC16 High
Byte [11]	0x93	CRC16 Low

- Locate the sensor module as following Figure 43. The sensor is ready for user to perform calibration step 1

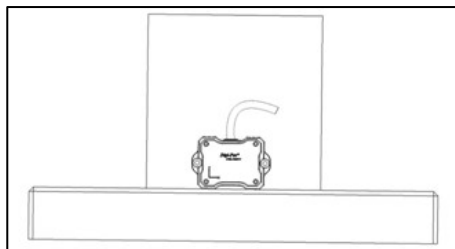

Figure 43. Tilt Sensor Module Position of Calibration Step 1

- Send the following command from computer to all sensors to trigger on the calibration step 1:

<< (To sensor): 0x06, 0x0B, 0x05, 0xB0, 0x00, 0x00, 0x00, 0x00, 0x00, 0x00, 0x00, 0x00

Byte [n]	Command	Descriptions
Byte [0]	0x06	From Computer
Byte [1]	0x0B	Calibration Mode
Byte [2]	0x05	To all sensors
Byte [3]	0xB0	Start current calibration step
Byte [4]~[11]	0x00	Not Applicable

- Wait for response from the sensors. The sensor will broadcast the following response with Byte 4 counting from 0x00 to 0x1E. Once Byte 4 counts to 0x1E, Byte 3 shows 0x17 from 0x0A and Byte 6 shows 0x02, calibration step 1 is completed. If Byte 3 from sensor response **is not equal** to 0x17 and Byte 6 response **is not equal** to 0x02 after Byte 4 is counted to 0x1E, restart (power off and power on again) the sensor module and redo the calibration process from the beginning (Step 1).

>> (From sensor): 0x71, 0x1B, 0x17, 0x1E, 0x13, 0x02, 0x88, 0xDD, 0xDD, 0xDD, 0x22, 0x93

Byte [n]	Command	Descriptions
Byte [0]	0x71	To control box / From Sensor 1
Byte [1]	0x1B	Single Axis Position / Calibration Mode
Byte [2]	0x17	Calibration Feedback : Idle
Byte [3]	0x1E	Calibration Count : 30
Byte [4]	0x13	Dummy
Byte [5]	0x02	Calibration Step 2 Ready
Byte [6]	0x88	Dummy
Byte [7]~[9]	0xDD	Fixed Dummy
Byte [10]	0x22	CRC16 High
Byte [11]	0x93	CRC16 Low

6. Locate the sensor module as following Figure 44. The sensor is ready for user to perform calibration step 2

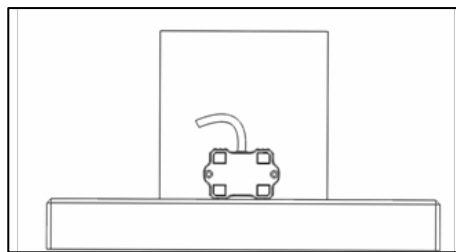

Figure 44. Tilt Sensor Module Position of Calibration Step 2

7. Repeat Step 4 to trigger the calibration step 2:

<< (To control box): 0x06, 0x01, 0x0B, 0xB0, 0x00, 0x00, 0x00, 0x00, 0x00, 0x00, 0x00, 0x00

8. Repeat Step 4 to trigger the calibration step 2:

<< (To control box): 0x06, 0x01, 0x0B, 0xB0, 0x00, 0x00, 0x00, 0x00, 0x00, 0x00, 0x00, 0x00\

9. Wait for response from the sensor. The sensor will broadcast the following response with Byte 4 counting from 0x00 to 0x1E. Once Byte 4 counts to 0x1E, Byte 3 shows 0x17 from 0x0A and Byte 6 shows 0x03, calibration step 2 is completed. If Byte 3 from sensor response **is not equal** to 0x17 and Byte 6 response **is not equal** to 0x03 after Byte 4 is counted to 0x1E, restart (power off and power on again) the sensor module and redo the calibration process from the beginning (Step 1).

>> (From control box): 0x71, 0x1B, 0x17, 0x1E, 0x13, 0x03, 0x88, 0xDD, 0xDD, 0xDD, 0x22, 0x93

Byte [n]	Command	Descriptions
Byte [0]	0x71	To control box / From Sensor 1
Byte [1]	0x1B	Single Axis Position / Calibration Mode
Byte [2]	0x17	Calibration Feedback : Idle
Byte [3]	0x1E	Calibration Count : 30
Byte [4]	0x13	Dummy
Byte [5]	0x03	Calibration Step 3 Ready
Byte [6]	0x88	Dummy
Byte [7]~[9]	0xDD	Fixed Dummy
Byte [10]	0x22	CRC16 High
Byte [11]	0x93	CRC16 Low

10. For **DWL5000XY** model, repeat step 3 to step 8. Please locate the sensor module in following positions (refer to Figure 45 to Figure 50) respectively.
11. For **DWL5500XY & DWL5800XY** model, please perform only 4 steps calibration as shown in Figure 43, 44, 49, and 50.
12. Once the following response is received, the calibration process is completed.

>> (From control box): 0x71, 0x2B, 0x17, 0x1E, 0x13, 0x08, 0x88, 0xDD, 0xDD, 0xDD, 0x22, 0x93

The sensor module will automatically change to dual axis mode and broadcast dual axis angle measurement (Please refer to 7.4.2 Dual Axis Mode) after the calibration process is completed.

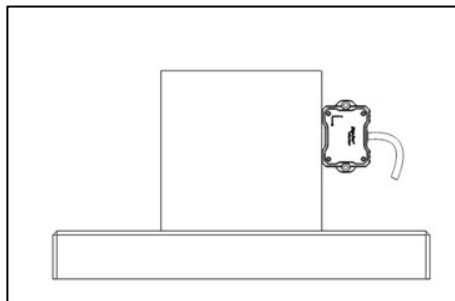

Figure 45. Tilt Sensor Module Position of Calibration Step 3

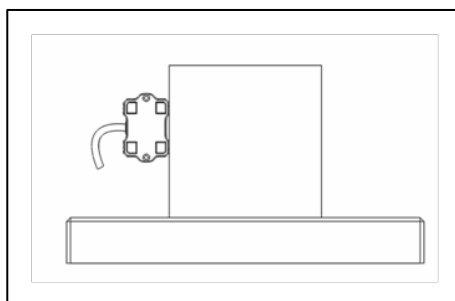

Figure 46. Tilt Sensor Module Position of Calibration Step 4

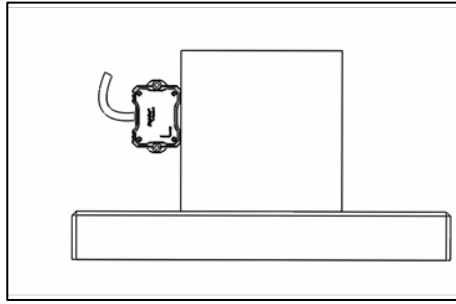

Figure 47. Tilt Sensor Module Position of Calibration Step 5

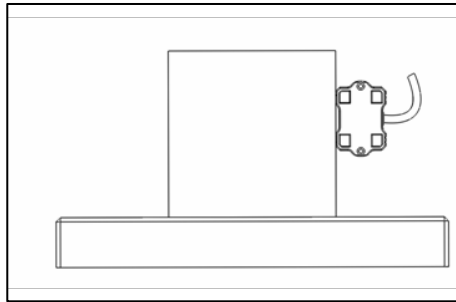

Figure 48. Tilt Sensor Module Position of Calibration Step 6

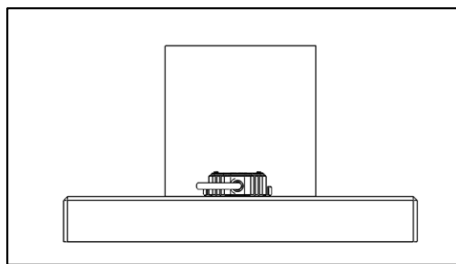

Figure 49. Tilt Sensor Module Position of Calibration Step 7

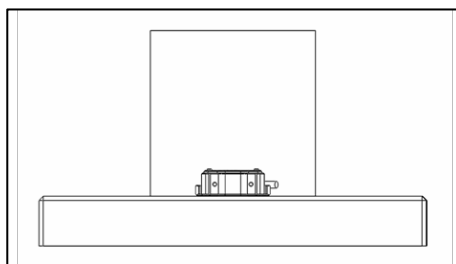

Figure 50. Tilt Sensor Module Position of Calibration Step 8

8.4.5. Relay Mode

To trigger the relay output:

<< (To control box): 0x06, 0x20, 0x00, 0x6C, 0xCC, 0xBB, 0xBB, 0xBB, 0x00, 0x00, 0x00, 0x00

Byte [n]	Command	Descriptions
Byte [0]	0x06	From Computer
Byte [1]	0x20	Relay Mode
Byte [2]	0x00	Not Applicable
Byte [3]	0xCC	0xCC : Set Relay1 Output to Normally Open (NO) 0xBB : Set Relay1 Output to Normally Closed (NC)
Byte [4]	0xBB	0xCC : Set Relay2 Output to Normally Open (NO) 0xBB : Set Relay2 Output to Normally Closed (NC)
Byte [5]	0xBB	0xCC : Set Relay3 Output to Normally Open (NO) 0xBB : Set Relay3 Output to Normally Closed (NC)
Byte [6]	0xBB	0xCC: Set Relay4 Output to Normally Open (NO) 0xBB: Set Relay4 Output to Normally Closed (NC)
Byte [7]~[11]	0x00	Not Applicable

Data return from control box:

>> (From control box): 0x07, 0x06, 0x20, 0xAA, 0xBB, 0xBB, 0xBB, 0x00, 0x00, 0x00, 0x00, 0x00

Byte [n]	Command	Descriptions
Byte [0]	0x07	From Control Box
Byte [1]	0x06	To Computer
Byte [2]	0x20	Relay Mode
Byte [3]	0xAA	0xAA : Relay1 Output is set to Normally Open (NO) 0xBB : Relay1 Output is set to Normally Closed (NC)
Byte [4]	0xBB	0xAA : Relay2 Output is set to Normally Open (NO) 0xBB : Relay2 Output is set to Normally Closed (NC)
Byte [5]	0xBB	0xAA : Relay3 Output is set to Normally Open (NO) 0xBB : Relay3 Output is set to Normally Closed (NC)
Byte [6]	0xBB	0xAA : Relay4 Output is set to Normally Open (NO) 0xBB : Relay4 Output is set to Normally Closed (NC)
Byte [7]~[11]	0x00	Not Applicable

APPENDIX 1: USER CALIBRATION

Calibration Instruments:

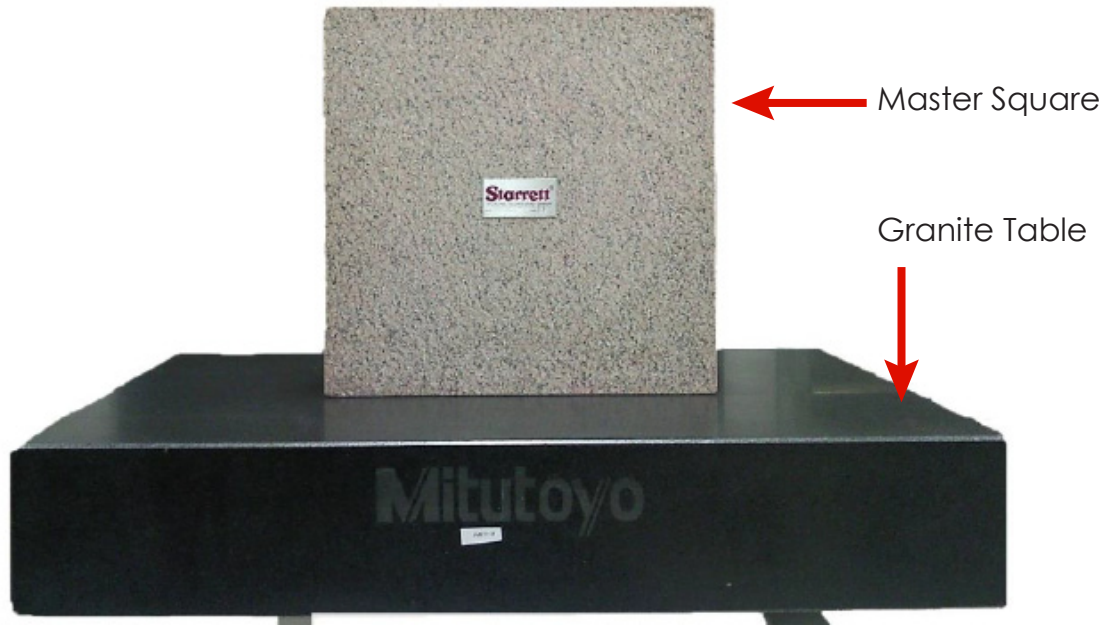

	DWL5000XY	DWL5500XY
Granite Table	Grade AA (Levelled to ≤ 10 arcsec)	Grade AA (Levelled to ≤ 1.0 arcsec)
Master Square	Flatness : $\leq 2.0\mu\text{m}$ Perpendicularity: $\leq 2.0\mu\text{m}$ Parallelism: $\leq 2.0\mu\text{m}$	Not Required
Number of Calibration Steps	8	4

** Allow sufficient time for device to warm up and stabilise after turning on the device.

** Hold the device firmly and do not move the device during calibration process.

APPENDIX 2: Country and City Index

Country	Country Index	City	City Index
Argentina	0x01	Tucuman	0x01
Argentina	0x01	Cordoba	0x02
Argentina	0x01	Rosario	0x03
Argentina	0x01	Buenos Aires	0x04
Argentina	0x01	Bahia Blanca	0x05
Argentina	0x01	Trelew	0x06
Argentina	0x01	Sarmiento	0x07
Australia	0x02	Darwin	0x01
Australia	0x02	Cairns	0x02
Australia	0x02	Salta	0x03
Australia	0x02	Alice Springs	0x04
Australia	0x02	Maryborough	0x05
Australia	0x02	Brisbane	0x06
Australia	0x02	Perth	0x07
Australia	0x02	Kempsey	0x08
Australia	0x02	Canberra	0x09
Australia	0x02	Sydney	0x0A
Australia	0x02	Albury	0x0B
Australia	0x02	Melbourne	0x0C
Australia	0x02	Hobart	0x0D
Austria	0x03	--	0x01
Bangladesh	0x04	--	0x01
Belgium	0x05	--	0x01
Bolivia	0x06	--	0x01
Brazil	0x07	Nova Lisboa	0x01
Brazil	0x07	Belem	0x02
Brazil	0x07	Brazilia	0x03
Brazil	0x07	Colombo	0x04
Brazil	0x07	Luanda	0x05
Brazil	0x07	Goiania	0x06
Brazil	0x07	Salvador	0x07
Brazil	0x07	Caravelas	0x08
Brazil	0x07	Sao Paulo	0x09
Brazil	0x07	Victoria	0x0A
Brazil	0x07	Rio de Janeiro	0x0B

Country	Country Index	City	City Index
Brazil	0x07	Porto Alegre	0x0C
Brazil	0x07	Pelotas	0x0D
Canada	0x08	Whitehorse	0x01
Canada	0x08	Fort McMurray	0x02
Canada	0x08	Prince George	0x03
Canada	0x08	Edmonton	0x04
Canada	0x08	Winnipeg	0x05
Canada	0x08	Saskatoon	0x06
Canada	0x08	Vancouver	0x07
Canada	0x08	Victoria	0x08
Canada	0x08	Calgary	0x09
Canada	0x08	Ottawa	0x0A
Canada	0x08	Quebec	0x0B
Canada	0x08	Montreal	0x0C
Canada	0x08	Toronto	0x0D
Chile	0x09	Puerto Montt	0x01
Chile	0x09	Santiago	0x02
Chile	0x09	Valparaiso	0x03
Chile	0x09	Arica	0x04
China	0x0A	Beijing	0x01
China	0x0A	Tianjin	0x02
China	0x0A	Shanghai	0x03
China	0x0A	Wuhan	0x04
China	0x0A	Dongguan	0x05
China	0x0A	Shantou	0x06
China	0x0A	Guangzhou	0x07
China	0x0A	Shenzhen	0x08
Colombia	0x0B	Bogota	0x01
Colombia	0x0B	Popayan	0x02
Colombia	0x0B	Medellin	0x03
Colombia	0x0B	Cali	0x04
Costa Rica	0x0C	--	0x01
Croatia	0x0D	--	0x01
Czech Republic	0x0E	--	0x01
Denmark	0x0F	Korsør	0x01
Denmark	0x0F	Copenhagen	0x02
Denmark	0x0F	Middelfart	0x03
Denmark	0x0F	Torshavn	0x04
Dominica	0x10	--	0x01
Ecuador	0x11	--	0x01

Country	Country Index	City	City Index
Egypt	0x12	--	0x01
El Salvador	0x13	--	0x01
Estonia	0x14	--	0x01
Finland	0x15	--	0x01
France	0x16	Lille	0x01
France	0x16	Paris	0x02
France	0x16	Strasbourg	0x03
France	0x16	Nantes	0x04
France	0x16	Lyon	0x05
France	0x16	Bordeaux	0x06
France	0x16	Marseille	0x07
France	0x16	Toulouse	0x08
Germany	0x17	Flensburg	0x01
Germany	0x17	Rostock	0x02
Germany	0x17	Hamburg	0x03
Germany	0x17	Bremen	0x04
Germany	0x17	Berlin	0x05
Germany	0x17	Hanover	0x06
Germany	0x17	Bielefeld	0x07
Germany	0x17	Essen	0x08
Germany	0x17	Leipzig	0x09
Germany	0x17	Dresden	0x0A
Germany	0x17	Cologne	0x0B
Germany	0x17	Frankfurt	0x0C
Germany	0x17	Nuremberg	0x0D
Germany	0x17	Munich	0x0E
Germany	0x17	Stuttgart	0x0F
Germany	0x17	Freiburg	0x10
Greece	0x18	--	0x01
Guatemala	0x19	--	0x01
Hong Kong	0x1A	--	0x01
Hungary	0x1B	--	0x01
India	0x1C	New Delhi	0x01
India	0x1C	Lucknow	0x02
India	0x1C	Ahmadabad	0x03
India	0x1C	Kolkata	0x04
India	0x1C	Mumbai	0x05
India	0x1C	Hyderabad	0x06
India	0x1C	Bangalore	0x07
India	0x1C	Chennai	0x08

Country	Country Index	City	City Index
Indonesia	0x1D	--	0x01
Ireland	0x1E	--	0x01
Israel	0x1F	--	0x01
Italy	0x20	Rome	0x01
Italy	0x20	Milan	0x02
Italy	0x20	Trieste	0x03
Japan	0x21	Wakkanai	0x01
Japan	0x21	Asahikawa	0x02
Japan	0x21	Sapporo	0x03
Japan	0x21	Aomori	0x04
Japan	0x21	Tohoku	0x05
Japan	0x21	Akita	0x06
Japan	0x21	Morioka	0x07
Japan	0x21	Sendai	0x08
Japan	0x21	Niigata	0x09
Japan	0x21	Mito	0x0A
Japan	0x21	Kanazawa	0x0B
Japan	0x21	Tokyo	0x0C
Japan	0x21	Yokohama	0x0D
Japan	0x21	Shizuoka	0x0E
Japan	0x21	Nagoya	0x0F
Japan	0x21	Kyoto	0x10
Japan	0x21	Osaka	0x11
Japan	0x21	Kobe	0x12
Japan	0x21	Okayama	0x13
Japan	0x21	Hiroshima	0x14
Japan	0x21	Matsuyama	0x15
Japan	0x21	Fukuoka	0x16
Japan	0x21	Kochi	0x17
Japan	0x21	Oita	0x18
Japan	0x21	Kumamoto	0x19
Japan	0x21	Kagoshima	0x1A
Japan	0x21	Naha	0x1B
Kenya	0x22	--	0x01
Korea	0x23	--	0x01
Latvia	0x24	--	0x01
Lithuania	0x25	--	0x01
Luxembourg	0x26	--	0x01
Macedonia	0x27	--	0x01
Malaysia	0x28	--	0x01

Country	Country Index	City	City Index
Mexico	0x29	Mexico City	0x01
Mexico	0x29	Puebla	0x02
Mexico	0x29	Guadalajara	0x03
Mexico	0x29	Leon	0x04
Mexico	0x29	San Luis Potosi	0x05
Mexico	0x29	Acapulco	0x06
Mexico	0x29	Torreon	0x07
Mexico	0x29	Monterrey	0x08
Mexico	0x29	Merida	0x09
Mexico	0x29	Cancun	0x0A
Mexico	0x29	Chihuahua	0x0B
Mexico	0x29	Ciudad Juarez	0x0C
Mexico	0x29	Mexicali	0x0D
Morocco	0x2A	Marrakech	0x01
Morocco	0x2A	Casablanca	0x02
Morocco	0x2A	Tangier	0x03
Myanmar	0x2B	--	0x01
Netherland	0x2C	--	0x01
New Zealand	0x2D	Auckland	0x01
New Zealand	0x2D	Wellington	0x02
New Zealand	0x2D	Christchurch	0x03
New Zealand	0x2D	Dunedin	0x04
Norway	0x2E	Oslo	0x01
Norway	0x2E	Soknedal	0x02
Norway	0x2E	Skogn	0x03
Norway	0x2E	Bodo	0x04
Norway	0x2E	Trondheim	0x05
Norway	0x2E	Sorkjosen	0x06
Norway	0x2E	Tromso	0x07
Norway	0x2E	Hammerfest	0x08
Panama	0x2F	--	0x01
Paraguay	0x30	--	0x01
Peru	0x31	Arequipa	0x01
Peru	0x31	Talara	0x02
Peru	0x31	Lima	0x03
Philippines	0x32	--	0x01
Poland	0x33	--	0x01
Portugal	0x34	--	0x01
Puerto Rico	0x35	--	0x01
Romania	0x36	--	0x01

Country	Country Index	City	City Index
Russia	0x37	--	0x01
Saudi Arabia	0x38	--	0x01
Singapore	0x39	--	0x01
Spain	0x3A	Rota	0x01
Spain	0x3A	Mallorca	0x02
Spain	0x3A	Barcelona	0x03
Sri Lanka	0x3B	--	0x01
Sweden	0x3C	Adak	0x01
Sweden	0x3C	Helsingborg	0x02
Sweden	0x3C	Venige	0x03
Sweden	0x3C	Apelviksaas	0x04
Sweden	0x3C	Hogstorp	0x05
Sweden	0x3C	Stockholm	0x06
Sweden	0x3C	Svinesund	0x07
Switzerland	0x3D	Basel	0x01
Switzerland	0x3D	Zurich	0x02
Switzerland	0x3D	Berne	0x03
Switzerland	0x3D	Lucerne	0x04
Switzerland	0x3D	Chur	0x05
Switzerland	0x3D	Lausanne	0x06
Switzerland	0x3D	Geneva	0x07
Taiwan	0x3E	--	0x01
Thailand	0x3F	Bangkok	0x01
Thailand	0x3F	Songkhla	0x02
Turkey	0x40	--	0x01
United Kingdom	0x41	Perth	0x01
United Kingdom	0x41	Glasgow	0x02
United Kingdom	0x41	Manchester	0x03
United Kingdom	0x41	Nottingham	0x04
United Kingdom	0x41	Birmingham	0x05
United Kingdom	0x41	London	0x06
United Kingdom	0x41	Bristol	0x07
United Kingdom	0x41	Sunderland	0x08
United States	0x42	Seattle	0x01
United States	0x42	Portland	0x02
United States	0x42	Boston	0x03
United States	0x42	Detroit	0x04
United States	0x42	Chicago	0x05
United States	0x42	New York	0x06
United States	0x42	Indianapolis	0x07

Country	Country Index	City	City Index
United States	0x42	Washington DC	0x08
United States	0x42	Columbus	0x09
United States	0x42	Saint Louis	0x0A
United States	0x42	Kansas City	0x0B
United States	0x42	San Francisco	0x0C
United States	0x42	Nashville	0x0D
United States	0x42	Charlotte	0x0E
United States	0x42	Memphis	0x0F
United States	0x42	Oklahoma City	0x10
United States	0x42	Denver	0x11
United States	0x42	Las Vegas	0x12
United States	0x42	San Diego	0x13
United States	0x42	Atlanta	0x14
United States	0x42	Dallas	0x15
United States	0x42	Los Angeles	0x16
United States	0x42	Phoenix	0x17
United States	0x42	Jacksonville	0x18
United States	0x42	Houston	0x19
United States	0x42	Fort Worth	0x1A
United States	0x42	Austin	0x1B
United States	0x42	Orlando	0x1C
United States	0x42	San Antonio	0x1D
United States	0x42	El Paso	0x1E
United States	0x42	Miami	0x1F
Uruguay	0x44	--	0x01
Venezuela	0x44	--	0x01
Vietnam	0x45	--	0x01

9. Warranty

Digi-Pas® 2-Axis Inclination sensor module is warranted to the original purchaser to be free from defects in workmanship and material. Digipas Technologies Inc. will, at its option, repair or replace any defective part which may malfunction under normal and proper use within a period of 2 (two) years from the date of purchase. The forgoing warranty shall not apply to defects resulting from misuse, abuse, assignment, or transfer by the Buyer. Buyer-supplied software or interfacing, unauthorized modification or operation outside of environment specifications for the product. JSB Tech does not warrant that the operation of instrument software, or firmware, will be uninterrupted or error free. The exclusive remedy under any and all warrants and guarantees, expressed herein, and we shall not be liable for damages from loss or delay of equipment uses, consequential, or incidental damage. No other Warranty is expressed or implied. JSB Tech specifically disclaims the implied warranties of merchantability and fitness for a particular purpose.

Distributed by :

Manufactured by:

JSB TECH PTE LTD

Email: info@digipas.com

www.digipas.com